

241

After Recording Return To:

K. Layne Morrill
Yachats Creekside Development, L.L.C.
One East Camelback Road
Suite 340
Phoenix, Arizona 85012

STATE OF OREGON } ss.
County of Lincoln

44 Pages

I, Dana W. Jenkins, County Clerk, in and for said county, do hereby certify that the within instrument was received for record, and recorded in the Book of Records of said county at Newport, Oregon. WITNESS my hand and seal of said office affixed.

DANA W. JENKINS, Lincoln County Clerk



Doc : 200807740
Rect: 805187 241.00
06/26/2008 12:36:56pm

Recorded by First American
Title Insurance Co.
Order # 08-155

**DECLARATION OF COVENANTS, CONDITIONS,
AND RESTRICTIONS**

CREEKSIDE

**A CLASS II PLANNED COMMUNITY
UNDER THE OREGON PLANNED COMMUNITY ACT**

TABLE OF CONTENTS

RECITALS	1
PURPOSE	1
ARTICLE 1: DESCRIPTION	1
1.1 Name	1
1.2 Location	1
1.3 Legal Description	1
1.4 Lots and Common Area	1
1.5 Oregon Planned Community Act	2
1.6 Declarant	2
1.7 Declarant Improvements	2
ARTICLE 2: COMMUNITY ASSOCIATION	2
2.1 Creation and Succession	2
2.2 Turnover Meeting	2
2.3 Powers and Obligations	2
2.4 Membership	2
2.5 Voting Rights	3
2.6 Bylaws	3
2.7 Member Meetings	3
2.8 Common Area Sales and Liens	3
ARTICLE 3: OWNERSHIP RIGHTS	3
3.1 Lots	3
3.2 Common Area	3
3.3 Easements	3
3.3.1 Platted Easements	4
3.3.2 Common Area	4
3.3.3 Encroachment	4
3.3.4 Association Easements	4
3.3.5 Government and Utility Easements	5
3.3.6 Declarant Easements	5
ARTICLE 4: CONSTRUCTION RESTRICTIONS	5
4.1 General Policy	5
4.2 Home Designs	5
4.3 Home Orientation, Setbacks, and Height Restrictions	6
4.4 Construction Time Requirements	6
4.5 Exterior Finish and Window Coverings	6
4.6 Lot and Home Maintenance	6
4.7 Auxiliary Structures	6
4.8 Landscaping and Outdoor Lighting	6
4.9.Common Area	7

ARTICLE 5: ARCHITECTURAL CONTROL COMMITTEE 7

5.1 Purpose and Authority 7

5.2 Membership: Appointment and Removal 7

5.3 Declarant’s Rights 7

5.4 Written Approval of Proposed Work 7

5.5 Approval Standards 8

5.6 Timing of Approval 8

5.7 Action Without Meeting 8

5.8 Effective Period of Approval 8

5.9 Right of Entry 8

5.10 Evidence of Compliance 8

5.11 Precedent Not Binding 9

5.12 No Liability 9

ARTICLE 6: USE RESTRICTIONS 9

6.1 Residential Use 9

6.2 Long Term Rentals 9

6.2.1 Term 9

6.2.2 Tenant Compliance 9

6.2.3 Member Liability 9

6.2.4 Suspension of Rental Rights 10

6.3 No Vacation Rental 10

6.4 Use of Common Area 10

6.5 Animals 10

6.6 Nuisance 10

6.7 Parking 10

6.7.1 Motor Vehicles 10

6.7.2 Street Parking 10

6.7.3 Recreation Vehicles 10

6.7.4 Vehicles in Disrepair 11

6.7.5 Violators Towed 11

6.7.6 Repairs 11

6.8 Garage 11

6.9 Signs 11

6.10 Utilities, Antennas, Clotheslines 11

6.11 Temporary Structures 11

6.12 Liability for Debris or Damage 11

6.13 Additional Rules 11

6.14 King Street 11

ARTICLE 7: ASSESSMENTS 12

7.1 Covenant to Pay Assessments 12

7.2 Uniform Rate of Assessment 12

7.3 Purpose of Assessments 12

7.4 Reserve Account 12

7.5 Regular Assessments 12

7.6 Commencement of Regular Association/Payments of Association Expenses. . . 13

7.7 Additional Assessments for Special Benefit 13

7.8 Special Assessments for Capital Improvements 13

7.9 Delinquency; Sanctions 13

7.10	Priority of Assessment Liens	14
7.11	Assessment Certificate	14
7.12	Transfer Fee	14
7.13	Surplus or Common Profits	14
ARTICLE 8: ENFORCEMENT		14
8.1	Association Sanctions	14
8.2	Emergency Procedure	14
8.3	Interest, Expenses, and Attorney Fees	15
8.4	Non-exclusiveness and Accumulation of Remedies	15
8.5	Effect of Breach	15
8.6	Effect of Nonenforcement	15
8.7	Nonliability	15
ARTICLE 9: GENERAL PROVISIONS		16
9.1	Severability	16
9.2	Duration	16
9.3	Amendment	16
9.4	No Right of Reversion	16
9.5	Rights of Mortgagees Relating to Maintenance	16
9.6	Insurance	16
9.7	Option to Purchase	17
9.8	Notices	17
9.9	Assignment	17
9.10	Indemnification	17
9.11	Jurisdiction and Venue	17
9.12	Interpretation	18

**DECLARATION OF
COVENANTS, CONDITIONS, AND RESTRICTIONS
CREEKSIDE
PLANNED COMMUNITY**

RECITALS

WHEREAS, Yachats Creekside Development, L.L.C., an Oregon limited liability company (hereafter referred to as “Declarant”), is record owner of certain real property located in the City of Yachats, more particularly described on **Exhibit “A”** hereto (the “Property”); and

WHEREAS, Declarant desires, for the benefit of all residents of the Creekside Planned Community to: (a) protect the native forest, Agency Creek, and ocean views; (b) provide for a consistent architectural theme; and (c) impose certain restrictions and easements.

NOW, THEREFORE, Declarant hereby imposes these declarations on the Property:

PURPOSE

For the purpose of protecting the value and desirability of the Property, it shall be managed, held, sold and conveyed as a planned community subject to the laws of the State of Oregon, ordinances of the City of Yachats, any other applicable government regulations, and the following covenants, conditions, restrictions, and easements (“CC&Rs”) which shall run with the Property and be binding on all parties having any right, title or interest in the Property or any portion thereof, their heirs, successors and assigns, and shall inure to the benefit of said parties and each of them.

ARTICLE 1

DESCRIPTION

1.1 **Name.** The name of the planned community is Creekside.

1.2 **Location.** Creekside is located entirely within the city limits of the City of Yachats, County of Lincoln, State of Oregon.

1.3 **Legal Description.** The legal description of all the Property included in Creekside is set forth on **Exhibit “A”** attached hereto and incorporated herein.

1.4 **Lots and Common Area.** Creekside is comprised of eight (8) individual lots (each a “Lot” and collectively the “Lots”), each of which shall be used for the construction of one single-family residence, and a Common Area for use by all the Members. A copy of the final plat depicting the Lots and the Common Area is set forth on **Exhibit “B”** attached hereto and incorporated herein. The legal descriptions of each Lot shall be with reference to the plat recorded on June 25, 2008 at 9:31 a.m. as Instrument No. 200867681 at Book 18 of Maps, Pages 32 and 32A of the records of the Lincoln County Recorder.

1.5 **Oregon Planned Community Act.** Creekside is a Class II Planned Community as defined in ORS § 94.550(4) and is subject to the Oregon Planned Community Act, ORS §§ 94.550 to 94.783.

1.6 Declarant. Declarant is the initial owner of the Property and the developer of Creekside. All Declarant's rights and obligations under this Declaration shall inure to and be binding upon Declarant's successors and assigns.

1.7 Declarant Improvements. Except as may be provided for under the terms of a separate contract between Declarant and an individual owner, Declarant has no obligation to provide landscaping or add improvements to any Lots. Declarant shall cause the Common Area to be improved with hiking trails, rest areas with benches, picnic areas, and related improvements as generally described on Exhibit "C" hereto with such modifications as seem necessary or appropriate during the course of construction of those improvements, as well as a small shelter south of Lot 4 and north of Agency Creek.

ARTICLE 2

COMMUNITY ASSOCIATION

2.1 Creation and Succession. Declarant has created an Oregon non-profit mutual benefit corporation named "Creekside Community Association Inc." (the "Association"). The Association shall have property, powers, and obligations as set forth in this and other recorded declarations and covenants for the benefit of the Property and its Members. The existence of the Association shall be perpetual. However, if for any reason the entity operating as the Association is dissolved, the Members may create a new Oregon non-profit corporation entity to operate as the Association. All property, powers, and obligations of the Association shall automatically vest in such other Oregon non-profit corporation, or if one is not created, then all property, powers, and obligations of the Association shall automatically vest in an unincorporated association comprised of all the Members. The unincorporated association shall function to the fullest extent possible in accordance with this Declaration, Bylaws and any other applicable regulations existing at the time of the dissolution.

2.2 Turnover Meeting. In accordance with ORS § 94.609, Declarant shall call a special Member meeting ("Turnover Meeting") not later than 90 days after the earlier of: (a) six (6) Lots have been conveyed to individual owners other than the Declarant and other than a person or entity who controls, is controlled by, or under common control with the Declarant ("Declarant Affiliate"); or (b) the date on which Declarant elects by written notice to all Members to terminate its voting preferences (the "Termination Date"). The purpose of the Turnover Meeting is to transfer the administrative responsibility from Declarant to the Association in accordance with ORS § 94.616. If Declarant fails to call the Turnover Meeting within the time stated, any Member may do so. If at the time of the Turnover Meeting Declarant or Declarant's Affiliate have not completed sales of all Lots and construction of homes thereon, the Declarant shall continue to hold all of Declarant's rights hereunder, other than voting and administrative control, until such development is complete.

2.3 Powers and Obligations. The Association shall have the power and obligation to: (a) own, manage, maintain and administer the Common Area and facilities of the Creekside planned community; (b) administer and enforce this Declaration; (c) collect and disburse assessments and charges; and (d) take such actions and establish such rules and Bylaws as are deemed useful to the management and operation of the Association and Creekside in accordance with the provisions of this Declaration.

2.4 Membership. Each owner of one or more Lots in Creekside, including Declarant, is a Member of the Association. An owner is the person named as either the grantee on a duly executed and recorded deed or the vendee on a duly executed and recorded contract of sale. The holder of a security interest in a Lot is not an owner. Whenever a Lot is sold, membership is automatically transferred to the new owner effective upon recording of either the deed or the contract of sale. It

is the duty of each Member to provide the Association with the following: (a) a copy of the Member's recorded deed or the Member's recorded contract of sale; (b) the Member's current mailing address, facsimile number and email address; and (c) the Member's then current telephone number. If two or more persons own a Lot jointly, the owners jointly shall constitute one Member. If an entity owns a Lot, the entity shall designate in writing one natural person to act as the Member with respect to such entity.

2.5 Voting Rights. Except as provided herein, a Member shall have one (1) vote for each Lot owned. Until the day following the Turnover Meeting, Declarant shall have four (4) votes for each Lot owned. Unless otherwise provided in this Declaration or the Bylaws, a proposed action or resolution shall carry if approved by a simple majority of the total number of votes cast at a Member meeting at which a quorum is present. An abstention shall not count as a vote cast. A Member may vote by proxy, provided the proxy's authority is in writing and signed by the Member. If two or more persons own a Lot jointly, any one of the co-owners may vote unless the other co-owner(s) object(s), in which case the vote shall be deemed an abstention. No change in the ownership of a Lot shall be effective for voting purposes unless and until the Board is given actual written notice of such change and is provided satisfactory proof thereof.

2.6 Bylaws. The Association shall adopt Bylaws required under ORS § 94.635 which shall be recorded as provided in ORS § 94.625 (the "Bylaws").

2.7 Member Meetings. Member meetings shall be held as provided for in the Bylaws.

2.8 Common Area Sales and Liens. After the Turnover Meeting, the Association shall not convey any Common Area to another person or subject the Common Area to any lien or encumbrance without the prior approval of Members owning at least 87.5% of the Lots.

ARTICLE 3

OWNERSHIP RIGHTS

3.1 Lots. Title to each of the eight (8) Lots of Creekside as depicted on the final plat of Creekside shall be conveyed in fee to an owner. Title may be held by any person or entity, either singly or jointly, who may hold title to real property under the law of the State of Oregon. Title may be freely conveyed by an owner, but all conveyances are subject to covenants, conditions, restrictions, and easements of record, including this Declaration. For purposes of this Declaration, the contract vendee under the terms of a recorded contract of sale of a Lot is the owner. Holders of security interests in Lots are not owners or Members.

3.2 Common Area. Declarant shall convey the Common Area to the Association no later than sixty (60) days after the Turnover Meeting.

3.3 Easements. Deeds to individual Lots may, but are not required to, set forth the easements specified in this Article 3. Each Lot shall have the burden and benefit of the easements described herein, regardless of whether the easements are described in the Lot's deed of conveyance. An "easement holder" is the person who has the benefit of an easement over another person's property, which is the "encumbered property." An easement holder may not use an easement for any purpose other than the intended use of the easement. The owner of the encumbered property may use the encumbering easement to the extent that such use does not interfere with the easement holder's rights to use the easement. Easements in Creekside include the following:

3.3.1 Platted Utility Easements. Lots and the Common Area are subject to public and private utility easements shown on the recorded plat of Creekside and on any supplemental plat. Private utility easements are for the exclusive use of the Lot(s) to which the utilities provide service. An easement holder shall give notice to the owner(s) of the encumbered Lot(s) and to the Association at least two weeks prior to construction or repair within the easement, except in an emergency where reasonable notice shall be given, if possible. Within two (2) weeks after completion, the easement holder shall restore any property damaged in the course of the construction or repair. If the easement holder fails to do so, the Association may thereafter restore the damaged property and charge the easement holder for the cost of restoration. If the bill for such charge is not paid within ten (10) days of receipt, the unpaid amount, and all costs and attorneys' fees incurred by the Association in connection therewith, plus interest at a rate of twelve percent (12%) per annum compounded annually, shall become a lien on the easement holder's Lot.

3.3.2 Common Area. Every Member shall have a non-exclusive easement over the Common Area for the use and enjoyment of the Common Area. This easement is appurtenant to and shall pass with title to each Lot. Any Member may delegate the rights of use and enjoyment of the Common Area to the Member's family, tenants, or guests provided they reside within the Member's home in Creekside and provided said Member gives the Association advance written notice of any such delegation. As long as Declarant owns any Lot, Declarant and Declarant's Affiliate shall have a non-exclusive easement over the Common Area to carry out all activities necessary and convenient for discharging Declarant's obligations or exercising Declarant's rights, including but not limited to, the sale of Lots, the construction of homes and Common Area improvements, and all related activities. Easements over the Common Area are subject to the following conditions: (a) the right of the Association to limit the number of guests to use the Common Area; (b) the right of the Association to grant easements for public utilities or for other public purposes consistent with the intended use of the Common Area; and (c) the provisions of this Declaration, the Bylaws, and the rules and regulations established from time to time by the Association. Use of the Common Area for residential purposes is prohibited. No Member may use the Common Area in a manner that interferes with use of the Common Area by any other Member, Declarant, or the Association.

3.3.3 Encroachment. If an encroachment results from construction, reconstruction, or repair approved by Declarant or the Architectural Control Committee, or as a result of shifting, settlement or movement of any portion of Creekside, an easement for the encroachment exists to the extent that any Lot or Common Area encroaches on any other Lot or Common Area. An easement continues for maintaining the encroachment so long as the encroachment exists. This provision does not relieve any Member, Declarant, or the Association of liability for knowingly violating the recorded plat of Creekside or this Declaration. Where the action of a party creates an encroachment and, at any time prior to substantial completion of the action, the party has actual knowledge of or is made aware of the encroachment, the party may be held liable for monetary damages for the encroachment and subject to a court order to remove the encroachment.

3.3.4 Association Easements. The Association shall have, in addition to any other easements granted in this Declaration or in any other instrument, the following easements: (a) all non-utility easements set forth on the plat of Creekside; (b) an easement over each Lot for utilities; and (c) an easement over each Lot for installation and maintenance of landscaping installed by Declarant or the Association (if to be maintained by the Association). The Association shall also have such easements and licenses as Declarant may hereafter grant from time to time and shall have such easements and licenses over the Common Area and over individual Lots as are reasonably necessary to perform the duties and

obligations of the Association as stated in this Declaration, the Bylaws and rules and regulations of the Association, as they may be amended from time to time. The Association shall maintain its easements.

3.3.5 Government and Utility Easements. Government entities and utility companies shall have such easements and licenses over the Common Area and over individual Lots as are reasonably necessary to perform their functions.

3.3.6 Declarant Easements. Declarant hereby reserves perpetual easements under, over, and across the Common Area, and under, over and across the utility easement area of each Lot as shown on the final plat of Creekside for the purpose of erecting, installing, constructing, maintaining and operating sewers and drainage and irrigating systems, and pipes, wires, cables and conduits for lighting, heating, power, telephone and any other method of conducting and performing any public or quasi-public utility service or function beneath, upon, or above the surface of such Common Area and such utility easement areas. Within the easements consisting of the setback areas, no structure, fence, planting or other materials may be placed or permitted to remain which may damage or interfere with the installation or maintenance of such utilities or facilities, or which may change the direction of flow of water through drainage channels or facilities in the easements or which may obstruct or retard the flow of water through drainage channels in the easements; provided, however, with prior written approval of the Association, a Member may install fencing or plant flowers in the easement if the Member agrees to remove the same at the Member's expense whenever it is necessary to have access to the land surface or sub-surface within the easement for any purpose specified herein and conditioned upon the Member making all necessary provision for alternate drainage facilities within the Member's Lot if surface drainage or sub-surface drainage is interrupted or altered.

ARTICLE 4

CONSTRUCTION RESTRICTIONS

4.1 General Policy. Creekside is a small, theme-oriented community designed to create the ambience of a neighborhood from the first two decades of the 20th Century. It is intended that both the exteriors and interiors of homes in Creekside are in the craftsman or bungalow style of architecture and interior design. For this reason, architectural control is stricter than in larger, non-theme-oriented developments. Declarant believes that by enforcing strict architectural controls, both the picturesque ambience of Creekside and the favorable property values of homes in Creekside will be maintained.

4.2 Home Designs. Declarant or a Declarant Affiliate homebuilding company (the "Builder") will prepare the home design that may be built on each Lot in Creekside. Modifications to a design may be made with Declarant's approval and upon payment by the Lot owner of any additional expense charged by the designer and/or Builder, provided that no such modification detracts from or substantially alters the appearance of the exterior of the home. No home may be built in Creekside other than according to plans and specifications approved by Declarant or the Architectural Control Committee. No home in Creekside may be repainted, retrimmed, or remodeled in any way that changes the exterior appearance of the home other than according to plans and specifications approved by Declarant or the Architectural Control Committee. If a home in Creekside is partially or totally destroyed and the Member determines to repair or rebuild the home, the repair or rebuilding shall be done according to the same plans and specifications existing at the time the home was destroyed, except for any modifications that are approved in writing by the Declarant or the Architectural Control Committee. Manufactured homes are absolutely prohibited.

4.3 Home Orientation, Setbacks, and Height Restrictions. The orientation, setbacks, and height restrictions of each home shall comply with the home orientation, building envelopes, and height restrictions generally set forth on **Exhibit "D"** which may be modified by Declarant at the time the Lot is purchased. Factors to be considered in making any adjustments to **Exhibit D** at the time a Lot is purchased are the convenience of the Member, the convenience of other Members, and the effect on the overall appearance of Creekside and the views from homes to be constructed on each other Lot. No home in Creekside shall be remodeled or rebuilt in any way that changes the orientation, setbacks, or height restrictions of the structure other than according to plans and specifications approved by Declarant. Chimneys, cornices, overhangs and eaves may extend into the setbacks required on **Exhibit "D."**)

4.4 Construction Requirements. All construction of homes in Creekside shall be by the Builder. Construction of a home on a Lot by the Builder shall be started no later than the deadline agreed to in the Lot owner's purchase agreement, but in no event more than three (3) years after the original date of purchase of the Lot from Declarant. Construction of a home shall be completed, including exterior decoration, within one (1) year from the date of the start of construction, unless construction is delayed by circumstances beyond the Lot owner's control.

4.5 Exterior Finish and Window Coverings. The exterior finish of each home, including siding, roofing, trim, and color shall be compatible with the theme of Creekside and shall be approved for each home by Declarant at the time the Lot owner enters into a home construction contract with Builder. Repair or replacement of any part of the exterior of a home may only be done using the same materials and colors as those being repaired or replaced or a reasonable equivalent approved by the Association. Window coverings shall be curtains, shutters, drapes, shades, or blinds that are commercially manufactured or are of quality comparable to those that are commercially manufactured.

4.6 Lot and Home Maintenance. Each Member is responsible for keeping the Member's Lot clean and free from debris, and the Member's home, including the roof, clean and in good repair so as not to present an unsightly appearance. A Member shall promptly clean any debris from and repair any damage done to the Member's Lot or home. All landscaping planted by a Member shall be trimmed and maintained in accordance with good landscape maintenance practices.

4.7 Auxiliary Structures. Auxiliary structures including but not limited to a mailbox, newspaper delivery box, woodshed, barbecue, pet enclosure and the like, may be constructed or placed on each Lot subject to Declarant's or Association's prior written approval. No Lot may be entirely fenced in, however a small courtyard area may be fenced in on each Lot subject to Declarant's or Association's prior written approval. The appearance of any such auxiliary structure shall be unobtrusive, tasteful, and compatible with the theme of Creekside. No other structures or equipment may be placed on any Lot or home.

4.8 Landscaping and Outdoor Lighting. Declarant or the Builder shall provide landscaping and outdoor lighting on each Lot in accordance with the terms of the home construction contract. Each Member shall maintain the landscaping on his or her Lot. The Association shall maintain any landscaping installed on the Common Area. Outdoor lighting on each improved Lot shall be wired into the individual home and electricity costs shall be included in the homeowner's electric bill, and each Lot owner shall replace all outdoor lighting light bulbs and maintain, repair and replace the hardware. A member may add flowers and shrubs to the Member's Lot after the construction of the home, provided that such added landscaping is approved by the Architectural Control Committee and does not interfere with or replace existing landscaping. Except as stated above, a Member may not alter, remove or add to the landscaping or outdoor lighting on the Member's Lot.

4.9 Common Area. The Common Area shall constitute open space for the use and benefit of Members. No improvements shall be constructed in the Common Area other than hiking trails, picnic areas, rest areas with benches, small shelter, and related improvements that Declarant will construct. No commercial logging activity shall be carried out on the Common Area. The Common Area shall be maintained so as to preserve the natural beauty of the native forest and of Agency Creek. Trash receptacles serving the Common Area may be located only at places approved by the Declarant or the Architectural Control Committee and shall be screened from view in a manner approved by the Declarant or the Architectural Control Committee.

ARTICLE 5

ARCHITECTURAL CONTROL COMMITTEE

5.1 Purpose and Authority. The purpose of this Declaration is to provide for and require all improvements to be in harmony with the general plan of improvement of the Property in order to insure the highest quality of development. Therefore, all improvements not approved by or undertaken by the Declarant or the Builder shall require prior written approval of the Architectural Control Committee, which is the body charged with maintaining the quality of Creekside. The approval of plans and specifications submitted to the Architectural Control Committee may be withheld not only because of their non-compliance with any of the specific covenants, conditions, and restrictions contained in this Declaration, but also because of the dissatisfaction of the Association acting by and through the Architectural Control Committee with any and all other matters or things which, in the judgment of the Architectural Control Committee, would render the proposed structure, improvement or Lot alteration in any manner inharmonious with the general plan of improvement of Creekside.

5.2 Membership: Appointment and Removal. The Architectural Control Committee shall be composed of three members elected by a majority vote of the Association's Board of Directors. At the first such election, one member shall be elected to serve a one-year term, one member shall be elected to serve a two-year term, and one member shall be elected to serve a three-year term, so that the terms of the three members will be staggered, one ending each year. The nominee receiving the highest number of votes shall be a three (3) year Director, the next highest number of votes shall be the two (2) year Director, and the third highest number of votes shall be the one (1) year Director. If any member of the Architectural Control Committee is unable or unwilling to act, the Association's Board of Directors shall elect a successor to serve out the unexpired term. No member of the Architectural Control Committee shall receive compensation for his or her services. The members of the Architectural Control Committee are officers of the Association.

5.3 Declarant's Rights. With respect to construction of improvements or alterations on Members' Lots which is subject to Declarant's approval, Declarant alone shall act in place of the Association and the Architectural Control Committee in exercising the rights and fulfilling the obligations given under this Article.

5.4 Written Approval of Proposed Work. Except for construction, repair, replacement, modification or landscaping approved by Declarant, no home or any structure or improvement of any kind or nature, including landscaping, shall be commenced, erected, placed or altered on any Lot until the construction plans and specifications, and a plan showing the nature, shape, height, materials and colors together with detailed plans showing the proposed location of the same on the particular Lot and the proposed landscaping and drainage have been submitted to and approved in writing by the Architectural Control Committee. All plans and specifications for approval by the Architectural Control Committee must be submitted at least forty-five (45) days prior to the start of construction unless a shorter time is approved in writing by the Architectural Control Committee.

The Architectural Control Committee may condition its approval of proposals and plans and specifications as it deems appropriate, and may require submission of additional plans and specifications or other information prior to approving or disapproving material already submitted. All decisions of the Architectural Control Committee, including without limitation, approvals, disapprovals and waivers, shall be in writing and shall require the consent of at least two of its members.

5.5 Approval Standards. The Architectural Control Committee shall not approve any proposed work if it finds the proposed work would be inappropriate for the particular Lot or incompatible with the design standards of Creekside. In making its decision, the Architectural Control Committee shall take into consideration the siting, shape, color, design, height, view impairment, and any other factors which the Committee reasonably finds material and relevant. If the Architectural Control Committee does not approve a proposed work, it shall provide the applicant with a specific written description of the reason(s) for not granting approval, so that the applicant may have a meaningful basis for modifying the proposal to meet with the Committee's approval.

5.6 Timing of Approval. In the event the Architectural Control Committee fails to approve or disapprove plans and specifications within forty-five (45) days after such plans and specifications have been submitted to it, the submitted plans and specifications shall be deemed approved. The forty-five (45) day time for response shall be deemed complied with if the Architectural Control Committee's notice is provided to the applicant in person or mailed within forty-five (45) days as determined by the date of mailing by the Committee. Such notice shall be delivered or mailed to the applicant at the address designated by the applicant for such purpose in his or her application.

5.7 Action Without Meeting. Except as otherwise provided herein, any two members of the Architectural Control Committee shall have the power to act on behalf of the Architectural Control Committee without the necessity of meeting and without the necessity of consulting with the remaining member of the Committee, if such consultation cannot occur in a timely fashion. Such members shall render their decision by written document setting forth the action taken and signed by both approving Members.

5.8 Effective Period of Approval. If construction on the proposed work is not commenced within one (1) year after the date of approval, the approval is automatically revoked unless the effective time of the approval is extended in writing by the Architectural Control Committee.

5.9 Right of Entry. Any officer or duly authorized agent of the Association, including any member of the Architectural Control Committee, may, at any reasonable hour or hours during construction or remodeling, enter and inspect any Lot or home as to its maintenance or improvements to determine if there has been compliance with the approved plans and specifications and with the provisions of this Declaration. The Association, and any officer or duly authorized agent thereof, shall not thereby be deemed guilty of any manner of trespass, invasion of privacy, or other legal wrong for such entry or inspection. The Association may issue a certificate of completion and compliance as to any property so inspected after all construction or repair has been completed.

5.10 Evidence of Compliance. Records of the Association with respect to compliance with the provisions of this Declaration shall be conclusive evidence as to all matters shown by such records to the extent the same are available. Records demonstrating compliance with the provisions of this Declaration may be provided to the County Clerk for recording in the records of the Lincoln Country Recorder by the Member receiving approval. Issuance of a certificate of completion and compliance by an officer of the Association showing that the plans and specifications for the

improvements or other matters herein provided for have been approved and that such improvements have been made in accordance therewith, or a certificate as to any matter relating to this Declaration by an officer of the Association shall be conclusive evidence that shall justify and protect any title company insuring title to any property subject to this Declaration and shall fully protect any purchaser or encumbrance holder in connection therewith. After the expiration of one (1) year following the issuance of a building permit therefor by municipal or other governmental authority, and written notice thereof is delivered to the Architectural Control Committee, any structure, work, improvement, or alteration shall be deemed to be in compliance with the provisions hereof unless a notice of non-compliance executed by the Association shall have been recorded in the office of the Lincoln County Recorder, or unless legal proceedings have been instituted to enforce compliance or completion.

5.11 Precedent Not Binding. The Architectural Control Committee shall treat each application for approval on a case by case basis. The Committee is not bound to approve a proposed work solely because it previously approved a similar work, and the Committee is not bound to disapprove a proposed work solely because it previously disapproved a similar work.

5.12 No Liability. Neither the Architectural Control Committee as a whole nor any individual member of the Committee shall be liable to any Member, occupant, builder, architect, developer, or any other person or entity for any damage, loss or prejudice claimed to have been suffered as a result of any decision made by the Committee, provided that the Committee or the individual member of the Committee acted in good faith in making the decision.

ARTICLE 6

USE RESTRICTIONS

6.1 Residential Use. Lots shall be used exclusively for single family homes. Unless authorized by the Association, no trade, craft, business, profession, or commercial or similar activity shall be conducted on any Lot or in any home, nor shall any goods, equipment, vehicles, materials or supplies used in connection with any trade, service or businesses be kept or stored on any Lot or in any home. The Association may authorize any of the restricted uses that is otherwise lawful if it determines that only normal residential activities would be observable outside the home and that the use would not be in violation of applicable government ordinances. Approval by the Association does not constitute approval by the applicable governmental agency. Members and Declarant may use Lots and homes for any of the following purposes without Association authorization: (a) activities relating to the sale or resale of homes in Creekside; (b) activities relating to the construction of homes or facilities in Creekside; (c) maintaining a personal, professional or business library; (d) maintaining personal, professional or business records and accounts; (e) handling personal, professional or business telephone calls and faxes; (f) using a computer for personal, professional or business matters; and (g) conferring with personal, professional or business associates, clients and customers.

6.2 Long Term Rentals. Members may rent homes in Creekside to third parties on the following conditions:

6.2.1 Term. The term of the rental is not less than thirty (30) days.

6.2.2 Tenant Compliance. Tenants shall comply with the provisions of this Declaration, Association Bylaws, and all other applicable rules and regulations.

6.2.3 Member Liability. Members shall be liable for their tenants' violations of this Declaration, the Bylaws, or any other applicable rules and regulations.

6.2.4 Suspension of Rental Rights. If a tenant or series of tenants renting a home violate(s) this Declaration, Association Bylaws, or any other applicable rules and regulations two (2) or more times within any 12-month period, the Association may suspend the Member's rental rights for a period of up to 12 months.

6.3 No Vacation Rental. No Member shall rent any Lot or home in Creekside for periods of less than thirty (30) days.

6.4 Use of Common Area. No Member shall place or cause to be placed on any portion of the Common Area, any trash, structure, equipment, improvement, furniture, package or object of any kind, except as may be allowed in proper designated receptacles. Such areas shall be used for no purpose other than as open space, hiking and picnicking. All Common Areas are provided for the use of the Members and their guests. Rules and regulations may be adopted by the Board of Directors, setting out the hours the various facilities will be available for use, and the conditions attendant thereto. Compliance with such rules and regulations as determined by the Board of Directors is essential to the harmonious operation of the facilities. In addition, Agency Creek (the "Creek"), located in the Common Area, shall constitute open space for the benefit of all Members of Creekside. No Member shall use the Creek in any manner which, in the sole opinion of the Directors, would constitute a nuisance, interfere with the normal flow of the Creek, or cause damage to the use and enjoyment of the Creek for all Members of Creekside or downstream property owners.

6.5 Animals. Except for a maximum of two (2) common household pets which may not be used for commercial purposes and which must be controlled so as not to be a nuisance, no animals, livestock, or poultry may be bred, raised or kept on any Lot. A pet owner shall be liable for any nuisance or damage caused by the pet. Upon the request of any Member, the Board shall determine, in its sole and absolute discretion, whether, for the purposes of this Section 6.5, a particular animal is a common household pet or whether a particular animal is a nuisance. Every dog must be on a leash and may not enter any Lot other than its owner's Lot. Pet owners are responsible for cleaning up after pets and pets may not be left unattended in vehicles in Creekside. The Association may compel a Member to remove a pet from Creekside if a Member violates this provision two (2) or more times.

6.6 Nuisance. No noxious, harmful, offensive, or unlawful activities may be carried on within Creekside, nor may a Member engage in any activity that unreasonably interferes with or jeopardizes the enjoyment of the other Members. Whether any particular activity violates this provision is to be determined by the Association on a case by case basis. No Member will permit any use of his or her Lot or make any use of the Common Area that will increase the cost of insurance to the Association.

6.7 Parking. No vehicle of any kind may be parked on any Lot or in the Common Area of Creekside except in accordance with the conditions below.

6.7.1 Motor Vehicles. Motor vehicles owned or in the custody of any Member may be parked only in a garage located upon such Member's Lot. Any vehicle which is not so parked may not be kept on the Lot.

6.7.2 Street Parking. Street parking is restricted to approved deliveries, pickup, or short-term guests or invitees.

6.7.3 Recreation Vehicles. Recreational vehicles such as campers, RVs, camp trailers, boats, motor homes, off-road vehicles, and similar vehicles may not be parked in any open parking space or any open area or on any Lot in Creekside. A recreational vehicle may be parked in a garage provided the garage door can be fully closed.

6.7.4 Vehicles in Disrepair. Vehicles that are inoperable, or in disrepair may not be parked in any open parking space or any open area or on any Lot. A vehicle that is inoperable or in disrepair may be parked in a garage provided the garage door can be fully closed.

6.7.5 Violators Towed. Vehicles parked in violation of this provision shall be subject to towing at the vehicle owner's expense, in addition to any other remedies available to any Member or the Association.

6.7.6 Repairs. No vehicle shall be repaired or rebuilt on any Lot or upon the Common Areas or public streets.

6.8 Garage. No vehicle may be parked in a garage in such a way that the garage door cannot be fully closed. All garage doors shall be closed except when vehicles are entering or exiting.

6.9 Signs. No sign of any kind shall be displayed to public view on any Lot, improvement, or Common Area, except one sign professionally made and approved by the Architectural Control Committee of not more than four (4) square feet posted on a Lot and advertising for sale the Lot or the home located on it. This restriction shall not prohibit the temporary placement of political signs by a Member on the Member's own Lot, or placement of a professionally made sign by Declarant, which complies with local applicable sign ordinances. This restriction does not apply to signs used by Declarant during construction and sales of homes.

6.10 Utilities, Antennas, Clotheslines. No outdoor overhead wire or service drop or other facility for the distribution of electric energy or for telecommunications purposes, nor any pole, tower or other structure supporting outdoor overhead wires shall be erected, placed or maintained within Creekside. All Members shall use underground service wires to connect their premises and the structures built thereon to the underground electric, telephone, utility, fiber optics, or cable television facilities provided, except as mandated by local jurisdiction or public utility companies. One satellite dish eighteen (18) inches in diameter or less may be allowed upon each Lot upon the Member's application for installation and written approval of Declarant or the Architectural Control Committee. Other antennas of any kind are prohibited. Exterior clotheslines are prohibited.

6.11 Temporary Structures. No trailer, tent, shack, garage, barn, other outbuilding or any other structure of a temporary nature may be erected or placed in Creekside.

6.12 Liability for Debris or Damage. Each Member is liable for debris on or damage to the Common Area caused by the Member, including without limitation, the Member's guests, tenants, contractors, employees, agents, and invitees. Each Member is liable for debris on or damage to any other Member's Lot caused by the Member, including without limitation, the Member's guests, tenants, contractors, employees, agents, and invitees.

6.13 Additional Rules. Rules and regulations concerning other use of the Property may be made and amended from time to time by the Board of Directors. Copies of such rules and regulations will be furnished to all Members and residents of the Project, upon request.

6.14 King Street. Neither the Declarant, a Declarant Affiliate, nor any Member shall remonstrate against the future formation of a local improvement district for the purpose of widening King Street.

ARTICLE 7

ASSESSMENTS

7.1 Covenant to Pay Assessments. Each Member, upon recording of a deed or contract of purchase of a Lot, regardless of whether reference is made to this Declaration or to Creekside assessments in the deed or other instrument of conveyance, is deemed to covenant and agree to pay to the Association: (a) regular assessments; (b) special assessments for capital improvements; and (c) additional assessments for special services provided to his or her Lot. Such assessments shall be fixed, established and collected as hereinafter provided.

7.2 Uniform Rate of Assessment. All regular assessments and assessments for capital improvements must be fixed at a uniform and equal rate per Lot. If special services are rendered to specific Lots at the request of the Members owning the Lots, as a result of a Member's default of any obligation set forth in this Declaration or in the Bylaws, or pursuant to any other provisions of this Declaration or the Bylaws, additional assessments shall be charged to such Lots for the special services rendered.

7.3 Purpose of Assessments. A regular assessment is a Member's obligation to pay a fixed amount of money to the Association each year for each Lot in Creekside owned by the Member. Regular assessments shall be levied by the Association against all Lots. Funds collected from regular assessments shall be used for: (a) administrative expenses of the Association, including without limitation, utilities, equipment, supplies, office space, insurance, professional services, and other services; (b) maintenance and repair of the common property, including without limitation, landscaping, walkways, bridges, and utilities; (c) maintenance and repair of landscaping and outdoor lighting on all Lots; and (d) funding the reserve account. An additional assessment is a Member's obligation to pay for services rendered that benefit the Member or Member's Lot made at the request of the Member, or due to the Member's default in fulfilling any of the Member's obligations under this Declaration or under the Bylaws. A special assessment for capital improvements is a Member's obligation to pay for their share of capital improvements related to the Common Area.

7.4 Reserve Account. Declarant shall establish a reserve account for replacement of all items of Common Area property that will require replacement. The reserve account established under this section shall be funded out of a portion of the regular assessments against the Lots. The amounts assessed shall take into account the estimated remaining life of the items for which the reserve is created and the projected replacement costs of those items. The reserve account shall be established in the name of the Association, which shall be responsible for administering the account and making periodic payments into it. The Association shall study annually whether any adjustment should be made to the portion of the regular assessment funded to the reserve and shall make any necessary adjustments. The account may be used only for replacement of Common Area property and is to be kept separate from other assessments. However, after the Association has assumed responsibility for administration of Creekside, the Board of Directors and the Association may borrow funds from the reserve account to meet other temporary expenses. Funds borrowed to meet temporary expenses shall be repaid from special assessments or regular assessments over a reasonable period not to exceed one year. Assessments paid into the reserve account are the property of the Association and are not refundable to members upon sale of Lots.

7.5 Regular Assessments. The regular assessment amount for each Lot shall be in an amount determined initially by the Declarant and, after the Turnover Meeting, reviewed annually by the Board of Directors of the Association. Regular assessments shall be paid in periodic installments, not more frequently than monthly nor less frequently than annually, as determined by the Declarant prior to the Turnover Meeting and by the Board of Directors of the Association thereafter. Regular assessments are due and payable as to each Lot, regardless of whether the Lot is

improved. The amount of the regular assessment may be increased or decreased at either a regular or special Member meeting, provided that notice of the meeting clearly specifies that the subject of an increase or decrease in the amount of the regular assessment will be voted on at the meeting. An increase or decrease in the amount of the regular assessment shall require the vote of a majority of the Members attending a Member meeting, either in person or by proxy, at which a quorum is present.

7.6 Commencement of Regular Association/Payments of Association Expenses. Regular assessments for Creekside shall commence as to each Lot on the date it is conveyed to an Owner other than the Declarant and other than a Declarant Affiliate, or on the date a contract of sale is recorded to an Owner other than the Declarant and other than a Declarant Affiliate, and shall continue thereafter. Prior to the Turnover Meeting the Declarant shall pay all common expenses of Creekside not covered by regular assessments against Lots that have been conveyed to owners other than the Declarant or a Declarant Affiliate. Immediately after the Turnover Meeting, regular assessments shall commence as to all Lots still owned by the Declarant or a Declarant Affiliate and the Declarant shall have no further responsibility for common expenses of Creekside, other than payment of assessments made under this Article 7 as to Lots owned by the Declarant.

7.7 Additional Assessments for Special Benefit. In addition to the regular assessments, if a Member or Lot receives special services benefitting less than all of the Lots or Members, or if a Member defaults on any obligations under this Declaration or under the Bylaws, the Board of Directors shall make an additional assessment against the Lot(s) and Member(s) specially benefitted in an amount determined by the Board of Directors. An additional assessment under this Section 7.7 may be approved by a Majority of the Directors present at a meeting where a quorum is present; provided, however, that the Member(s) as to whom the additional assessment is proposed shall have received written notice of such Meeting not less than five (5) days prior to the date of the meeting.

7.8 Special Assessments for Capital Improvements. In addition to the regular assessments, the Association may levy special non-recurring assessments from time to time for the purpose of paying, in whole or in part, the cost of any construction or reconstruction or unexpected repair or replacement of any capital improvement in the Common Area. A special assessment may be passed at either a regular or special member meeting, provided that notice of the meeting clearly specifies that the subject of a special assessment will be voted on at the meeting. A special assessment shall require the vote of at least a majority of the Members attending a Member meeting, either in person or by proxy, at which a quorum is present. This section shall not prohibit the Directors from authorizing capital expenditures for such replacement, repairs or improvements from funds generated by regular assessments. Notwithstanding ORS § 94.704(11)(a), prior to the Turnover Meeting, the approval of the Declarant shall be required for any special assessment for capital improvements. A special Assessment shall be due on the date specified in the resolution adopted by the Members.

7.9 Delinquency; Assessment Lien and Enforcement. Any assessment which is not paid within ten (10) days of the due date is delinquent. A late charge of ten percent (10%) of the amount unpaid shall be added to a delinquent payment, and the assessment plus the late charge shall bear interest from the date of delinquency at the rate of twelve percent (12%) per year compounded annually until paid. A delinquent payment is a lien on the Lot against which it is levied. An authorized officer of the Association shall file a lien notice against the Lot in the office of the County Recorder of Lincoln County, Oregon, within one hundred twenty (120) days after delinquency, stating the amount of the assessment and the late charge together with interest. The aggregate amount of the assessment, late charge, interest, costs and reasonable attorneys' fees for filing and enforcement thereof, shall constitute a recorded lien on the Lot, including any improvement thereon, from the date the notice of delinquency is filed until the same has been paid or released. Such lien may be enforced by the Association in the manner provided by law with respect to liens on real

property. The owner of the Lot at the time the assessment becomes due shall be personally liable for the resulting expenses, costs, disbursements, expert witness fees and attorneys fees which shall also be secured by said lien, including additional attorneys fees incurred upon appeal. The owner at the time such assessment is incurred shall also be personally liable for any deficiency remaining unpaid after any foreclosure sale. No Member may avoid liability for the assessments provided for herein by non-use of the Lot or Common Area or by abandonment of the Lot. A Member selling a Lot shall be personally liable for all assessments levied against the Lot prior to and including the date of recording of the instrument of conveyance. Upon payment in full of all amounts owing, the Association shall execute and file a release of the lien.

7.10 Priority of Assessment Liens. An assessment lien is not extinguished by sale or transfer of the Lot on which it is fixed. However an assessment lien is subordinate to any prior mortgage or trust deed on the Lot, and a sale pursuant to foreclosure of such a mortgage or trust deed shall extinguish the assessment lien. In the event of the foreclosure of a mortgage or trust deed on a Lot against which the Association holds an assessment lien, the Association shall have all rights of a junior encumbrancer under the law.

7.11 Assessment Certificate. The Association shall, upon demand at any reasonable time, furnish a written assessment certificate, signed by an officer of the Association, setting forth whether the assessments on a specific Lot have been paid. The Association may charge a reasonable fee for the issuance of assessment certificates. An assessment certificate shall be conclusive evidence of payment of any assessment therein stated to have been paid.

7.12 Transfer Fee. Each purchaser of a Lot, other than a purchaser purchasing a Lot from the Declarant, shall pay to the Association immediately upon becoming the owner of the Lot a transfer fee in such amount as is established from time to time by the Board.

7.13 Surplus or Common Profits. Any surplus or common profits of the Association shall either be added to the reserve account or applied to reduce the next regular assessment, as the Board of Directors may determine.

ARTICLE 8

ENFORCEMENT

8.1 Association Sanctions. In the event of a violation of any provision of this Declaration, the Bylaws of the Association, or other rules adopted by the Association, the Association may impose one or more of the following sanctions: (a) suspend the violating Member's voting rights; (b) suspend the violating Member's rights to use the Common Area; (c) impose fines upon the violating Member as provided for in the Bylaws and rules and regulations of the Association; (d) enter the offending Lot and remove the cause of such violation, or alter, repair, or change the items which are in violation in such a manner as to correct them, in which case the Association may assess the violating Member 120% of the entire direct and indirect cost of the work done, which amounts shall immediately be payable to the Association; and (e) bring suit or action against the Member on behalf of the Association and other Members to enforce the violated provisions. Any monetary sanctions shall constitute a lien on the Member's Lot as provided in Section 7.9.

8.2 Emergency Procedure. If the Association determines that an emergency exists, any reasonable remedies may be taken to avert the emergency without giving prior notice to the violating Member, provided that notice shall be given as soon as reasonably possible thereafter. In all other cases, the Association shall give written notice to the violating Member stating: (a) the exact nature

of the violation; (b) the remedies that will be taken; and (c) that the violating Member has the right to request a hearing before the Association to contest its determination, provided that the Member makes the request within seven (7) days of receipt of the notice. If a hearing is requested in a timely manner, the Association shall set a place and time for the hearing and give the violating Member written notice of such place and time. Remedies shall not be imposed pending the hearing. After the hearing, the Association may decide to impose the original remedies, impose lesser remedies, or impose no remedies. The Association shall notify the Member of its decision. All assessed fines shall be paid immediately to the Association and deposited into the Association's general account.

8.3 Interest, Expenses, and Attorney Fees. Any amount other than assessments not paid to the Association when due in accordance with this Declaration or the Bylaws of the Association shall incur: (a) a late fee equal to five percent (5%) of the amount due; and (b) interest at the rate of twelve percent (12%) per year on the unpaid amount (including the late fee) compounded annually from the due date until paid. In the event the Association shall bring a suit or action to enforce this Declaration, to collect any money due to it, or to foreclose a lien, the Association shall be entitled to recover all costs and expenses incurred in connection with the suit or action, including the cost of a foreclosure title report, expert witness fees and such amount as the court may determine to be reasonable as costs and attorneys fees at trial and on appeal. Such costs and expenses shall be the personal obligation of the Member against whom they are assessed and shall constitute a lien on the Lot(s) owned by the Member against whom they are assessed.

8.4 Non-exclusiveness and Accumulation of Remedies. An election by the Association to pursue any remedy provided for violation of this Declaration shall not prevent concurrent or subsequent exercise of any other remedy permitted under this Declaration. The remedies provided in this Declaration are not exclusive but shall be in addition to all other remedies, including actions for damages and suits for injunctions and specific performance, available under this Declaration, Association Bylaws and rules and regulations, or applicable laws.

8.5 Effect of Breach. The breach of any of the covenants, conditions, or restrictions contained in this Declaration shall not defeat or render invalid the lien of any mortgage or deed of trust made in good faith for value as to any Lot, but these covenants, conditions and restrictions shall be binding upon and effective against any such mortgagee or trustee or owner thereof, whose title thereto is or was acquired by foreclosure, trustee's sale or otherwise.

8.6 Effect of Nonenforcement. No delay or omission by Declarant, the Association or any Member in exercising any right, power or remedy provided in the event of a breach of this Declaration shall be construed as a waiver thereof or acquiescence therein.

8.7 Nonliability. Neither the Declarant or any officer or director of Declarant shall be held liable to the Association or to any of its Members or to any third party beneficiary under this Declaration for monetary damages for conduct as Declarant or as a director or officer unless such conduct is a breach of its duty of loyalty to the Corporation or its Members; is not in good faith or involves intentional misconduct or knowing violation of law; constitutes an unlawful distribution; any transaction from which the Declarant or director or officer derived an improper personal benefit; and any act or omission in violation of Oregon Revised Statutes 65.361 to 65.367. Notwithstanding the foregoing, no qualified director shall be liable to the Corporation unless his or her conduct constitutes gross negligence or intentional misconduct.

ARTICLE 9

GENERAL PROVISIONS

9.1 Severability. Invalidation of any one or more of the provisions of this Declaration by judgment or court order shall in no way affect any other provision that shall remain in full force and effect.

9.2 Duration. The provisions of this Declaration shall run with and bind the land, and shall inure to the benefit of and be enforceable by Declarant, the Association, or any Member subject to this Declaration, their respective legal representatives, heirs, successors and assigns.

9.3 Amendment. Any provision of this Declaration, except the easements herein granted and except rights reserved to the Declarant, may be amended by a vote of Members entitled to cast not less than seventy-five percent (75%) of the votes at a meeting of the Members. Easements herein granted or received shall not be amended except by instrument signed and acknowledged by all of the Owners of the affected Property, and by the Association. Amendments affecting the rights of the Declarant and any amendment adopted prior to the Turnover Meeting cannot be adopted without the written consent of the Declarant. The president and secretary of the Association shall execute and certify any amendment so approved as being adopted in accordance with this Section 9.3 and ORS § 94.590, acknowledge their signatures before a notary public and cause the amendment to be recorded in the applicable records of Lincoln County, Oregon and the same is effective only upon recording.

9.4 No Right of Reversion. Nothing in this Declaration, or in any form of deed which may be used by Declarant in selling Creekside, or any part thereof, shall be deemed to vest or reserve in Declarant or the Association any right of reversion or reentry for breach or violation of any one or more of the provision hereof.

9.5 Rights of Mortgagees Relating to Maintenance. At any time that any part of the Common Area, or any other part of Creekside, or any home, Lot, or other building or improvement located thereon is not in accordance with this Declaration, the Association's Bylaws, or the rules and regulations, or is not properly maintained and kept in good order and repair to the extent reasonably necessary to protect and preserve the appearance and value thereof and the appearance and value of the remainder of Creekside, the record owner of any mortgage or trust deed upon any part of said real property or residence or building thereon, after giving written notice as hereinafter provided, shall be entitled to exercise the rights of the Member-mortgagor of such property as a Member of the Association, including the right to vote at all regular and special meetings of the Members of the Association for the lesser of: (a) a period of one (1) year following the date of such notice; or (b) the sale of the Lot to another owner. During said period, the mortgagee shall be given notice of all regular and special meetings of the Association, and the Member-mortgagor shall receive notice also and may attend the meeting as an observer. The notice shall quote this paragraph and shall be sent by Certified United States Mail, return receipt requested, to the Member-mortgagor, with a copy by regular mail to the Member's last known address. The mortgagee shall provide the Association with a copy of the notice along with evidence of mailing in compliance with this provision.

9.6 Insurance. Each Member shall carry, with an insurer reasonably acceptable to the Association, homeowners' insurance insuring any home, building, or other improvement on its Lot against fire and other standard risks; shall name the Association an additional insured on such policy; and shall provide the Association upon request with a certificate from the insurer that the insurance is in force and that the Association will be provided a copy of any cancellation notice sent to the Member.

9.7 Option to Purchase. In the event a home on a Lot is partially or totally destroyed and, at any time more than six (6) months after such destruction, the Member has not commenced or ceases to prosecute, the repair or reconstruction of the home, then upon written notice from the Association to the Member, the Association shall have the option to purchase the Lot and all improvements thereon for cash at its then fair market value. Fair market value shall be determined by appraisal by a reputable residential appraiser with at least five (5) years experience in the Central Oregon Coast area ("Qualified Appraiser") selected by the Association. If the Member is dissatisfied with the appraisal provided by the Association, the Member may within a period of thirty (30) days after receiving the Association's Appraisal, secure a second appraisal from a Qualified Appraiser and provide it to the Association within the time specified, the option price shall be the average of the two appraisals. If the Member fails to provide a second appraisal within the time allowed, the option price shall be the fair market value as determined by the appraiser selected by the Association. In determining fair market value, both Qualified Appraisers shall consider the extent of destruction and all anticipated costs of demolition, reconstruction, and repair. The option may be exercised by written notice given at any time within thirty (30) days after: (a) the Association's receipt of the second appraisal; or (b) expiration of the time within which the second appraisal can be avoided. If the option is exercised, the closing shall occur on the date selected by the Association, but not later than sixty (60) days after exercise of the option.

9.8 Notices. Unless otherwise provided herein, any notice required to be sent to any Member under the provisions of this Declaration shall be deemed to have been properly sent when mailed by regular first class mail, when sent via facsimile transmission or when sent by email to the last mailing address, facsimile number, or email address provided to the Association in writing by the Member.

9.9 Assignment. Any or all rights, powers and reservations of Declarant herein contained may be assigned to the Association or to any person or corporation or association which is now organized or which may hereafter be organized and which will assume the duties of Declarant hereunder pertaining to the particular rights, powers and reservations assigned; and upon such person, corporation or association evidencing its intent in writing to accept such assignment, have the same rights and shall, to the extent of such assignment, have the same rights and powers and be subject to the same obligations and duties as are given to and assumed by Declarant herein.

9.10 Indemnification. From the Association's assets on hand or obtainable by assessment, the Association shall indemnify, hold harmless and defend its officers, directors and members of the Architectural Control Committee (each an "Indemnified Party"), who by reason of being such, or as a result of the exercise of their duties as such, are a party or are threatened to be made a party to any threatened, pending, or contemplated action, suit or proceeding, whether civil or criminal, administrative or investigative; provided that such Indemnified Party reasonably believed his or her conduct was in the best interest of the Association, or not opposed to its best interests, and in the case of criminal proceeding, where the Indemnified Party had no reasonable cause to believe his or her conduct was unlawful. No indemnification shall be allowed in connection with: (a) a proceeding by or in the right of the Association in which the Indemnified Party was adjudged liable to the Association; or (b) any other proceeding charging improper personal benefit to the Indemnified Party or in which the Indemnified Party was adjudged liable on the basis that personal benefit was improperly received by the Indemnified Party. Indemnification, if warranted in accordance with the foregoing, may be had for costs and expenses (including attorneys fees), judgments, and settlement payments.

9.11 Jurisdiction and Venue. Any action brought to interpret or enforce this Declaration, or in any way relating to the subject matter of this Declaration, or in any way involving or relating to Declarant, the Association or Creekside, shall be brought in the Circuit Court of the State of

Oregon for the County of Lincoln. Any such action brought in any other jurisdiction or venue shall be removed to said court upon the motion of any party or upon the court's own motion.

9.12 Interpretation. If any provision of this Declaration is subject to more than one reasonable interpretation, the reasonable interpretation expressly or implicitly adopted by the Association shall become, for all purposes, the controlling interpretation.

IN WITNESS WHEREOF, the undersigned Declarant hereby sets its hand to this Declaration this 25th day of June in the year 2008.

YACHATS CREEKSIDE DEVELOPMENT L.L.C., an Oregon limited liability company

By: Chestnut Management Company, an Arizona corporation, Manager

By: [Signature]
K. Layne Morrill, President

STATE OF ARIZONA)
) ss.
County of Maricopa)

Personally appeared before me on June 25, 2008, K. Layne Morrill who being duly sworn did say that he was the President of Chestnut Management Company which is the Manager of Yachats Creekside Development, L.L.C., and that he signed this instrument on behalf of the company, and acknowledged this instrument to be its voluntary act and deed.

[Signature]
Notary Public for Arizona

My Commission Expires: June 10, 2009

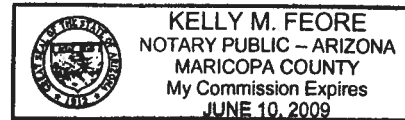

EXHIBIT "A"

(Legal Description of Property)

TRACT I:

Parcel 2, Partition Plat 14-1993, filed April 22, 1993, Partition Plat Records, Lincoln County, Oregon. TOGETHER WITH a non-exclusive easement for ingress and egress over a 50 foot wide strip of land as granted by the instrument dated March 1970, recorded May 27, 1970 in Book 18, page 1786, Microfilm Records of Lincoln County, Oregon.

TRACT II:

Parcel 3, Partition Plat No. 1997-21, filed October 23, 1997, Lincoln County Plat Records. TOGETHER WITH a non-exclusive easement for ingress and egress over a 50 foot wide strip of land as granted by the instrument dated March 1970, recorded May 27, 1970 in Book 18, page 1786, Microfilm Records of Lincoln County, Oregon.

Both Tract I and Tract II are TOGETHER WITH: (1) a 5 foot utility easement as set forth on Partition Plat No. 1997-21, filed October 23, 1997 in Lincoln County Plat Records; and (2) a 5 foot utility easement as set forth in instrument recorded March 6, 1998 in Book 353, page 741, Lincoln County Film Records.

EXHIBIT "B"
(Final Plat of Creekside)

**CREEKSIDE PLANNED UNIT DEVELOPMENT
A REPLAT OF PARCEL 3
OF PARTITION PLAT 1993 - 14
AND
PARCEL 2 OF PARTITION PLAT 1997 - 21
FOR
YACHTS CREEKSIDE DEVELOPMENT, LLC.
LOCATED IN THE
NORTH WEST 1/4 OF SECTION 26
TOWNSHIP 14 SOUTH, RANGE 12 WEST
WILLAMETTE MERIDIAN
CITY OF YACHTS
LINCOLN COUNTY, OREGON
APRIL 2008**

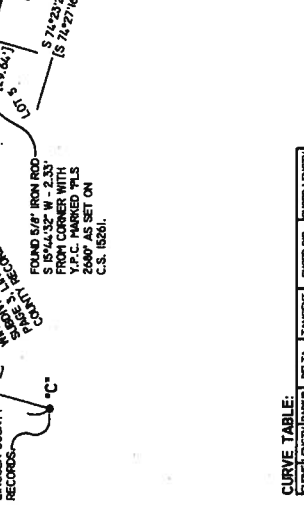
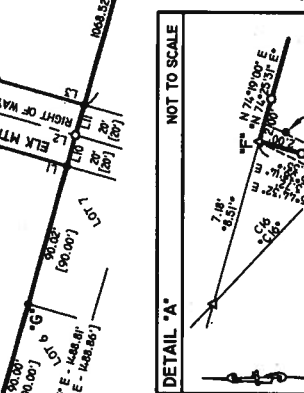
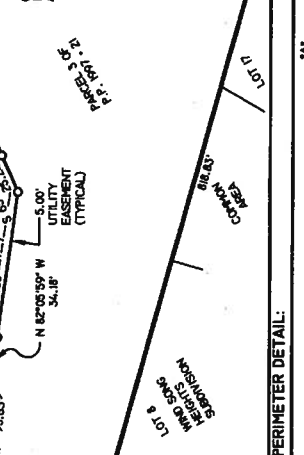
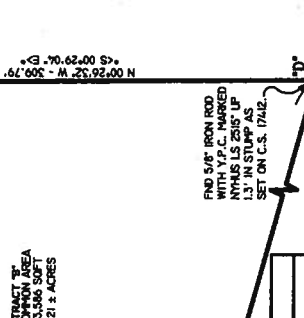
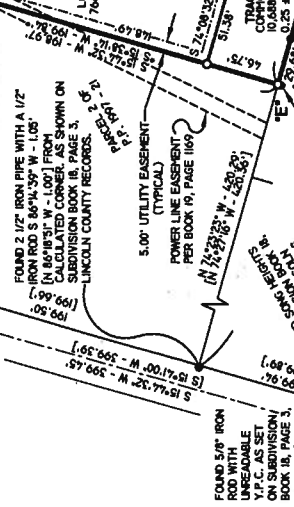
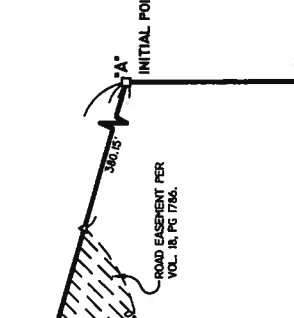
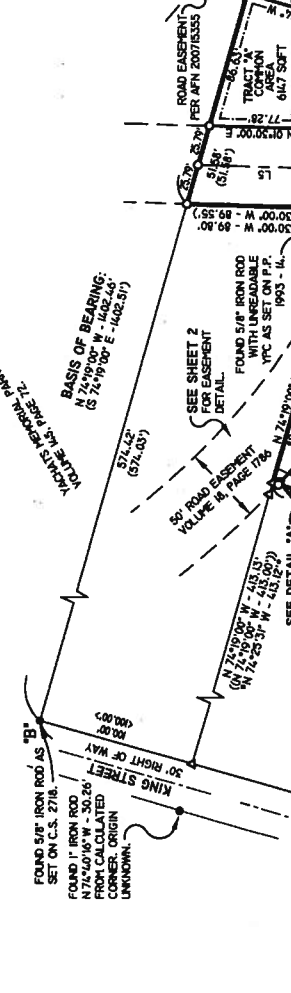
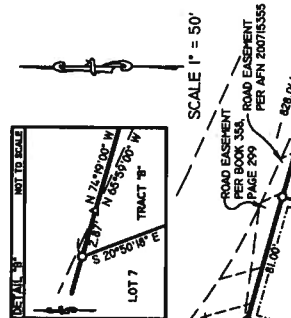

CURVE TABLE:

CHORD LENGTH	DELTA	TANGENT	CHORD BEAR	CHORD LENGTH
C1	24.32	44.00	S 84°14'32" E	24.32
C2	44.00	80.00	S 84°14'32" E	44.00
C3	80.00	156.99	S 84°14'32" E	80.00
C4	156.99	293.98	S 84°14'32" E	156.99
C5	293.98	539.96	S 84°14'32" E	293.98
C6	539.96	985.94	S 84°14'32" E	539.96
C7	985.94	1771.88	S 84°14'32" E	985.94
C8	1771.88	3543.76	S 84°14'32" E	1771.88
C9	3543.76	7087.52	S 84°14'32" E	3543.76
C10	7087.52	14175.04	S 84°14'32" E	7087.52
C11	14175.04	28350.08	S 84°14'32" E	14175.04
C12	28350.08	56700.16	S 84°14'32" E	28350.08
C13	56700.16	113400.32	S 84°14'32" E	56700.16
C14	113400.32	226800.64	S 84°14'32" E	113400.32
C15	226800.64	453601.28	S 84°14'32" E	226800.64
C16	453601.28	907202.56	S 84°14'32" E	453601.28
C17	907202.56	1814405.12	S 84°14'32" E	907202.56
C18	1814405.12	3628810.24	S 84°14'32" E	1814405.12
C19	3628810.24	7257620.48	S 84°14'32" E	3628810.24
C20	7257620.48	14515240.96	S 84°14'32" E	7257620.48
C21	14515240.96	29030481.92	S 84°14'32" E	14515240.96
C22	29030481.92	58060963.84	S 84°14'32" E	29030481.92
C23	58060963.84	116121927.68	S 84°14'32" E	58060963.84
C24	116121927.68	232243855.36	S 84°14'32" E	116121927.68
C25	232243855.36	464487710.72	S 84°14'32" E	232243855.36
C26	464487710.72	928975421.44	S 84°14'32" E	464487710.72
C27	928975421.44	1857950842.88	S 84°14'32" E	928975421.44
C28	1857950842.88	3715901685.76	S 84°14'32" E	1857950842.88
C29	3715901685.76	7431803371.52	S 84°14'32" E	3715901685.76
C30	7431803371.52	14863606743.04	S 84°14'32" E	7431803371.52
C31	14863606743.04	29727213486.08	S 84°14'32" E	14863606743.04
C32	29727213486.08	59454426972.16	S 84°14'32" E	29727213486.08
C33	59454426972.16	118908853944.32	S 84°14'32" E	59454426972.16
C34	118908853944.32	237817707888.64	S 84°14'32" E	118908853944.32
C35	237817707888.64	475635415777.28	S 84°14'32" E	237817707888.64
C36	475635415777.28	951270831554.56	S 84°14'32" E	475635415777.28
C37	951270831554.56	1902541663109.12	S 84°14'32" E	951270831554.56
C38	1902541663109.12	3805083326218.24	S 84°14'32" E	1902541663109.12
C39	3805083326218.24	7610166652436.48	S 84°14'32" E	3805083326218.24
C40	7610166652436.48	15220333304872.96	S 84°14'32" E	7610166652436.48
C41	15220333304872.96	30440666609745.92	S 84°14'32" E	15220333304872.96
C42	30440666609745.92	60881333219491.84	S 84°14'32" E	30440666609745.92
C43	60881333219491.84	121762666438983.68	S 84°14'32" E	60881333219491.84
C44	121762666438983.68	243525332877967.36	S 84°14'32" E	121762666438983.68
C45	243525332877967.36	487050665755934.72	S 84°14'32" E	243525332877967.36
C46	487050665755934.72	974101331511869.44	S 84°14'32" E	487050665755934.72
C47	974101331511869.44	1948202663023738.88	S 84°14'32" E	974101331511869.44
C48	1948202663023738.88	3896405326047477.76	S 84°14'32" E	1948202663023738.88
C49	3896405326047477.76	7792810652094955.52	S 84°14'32" E	3896405326047477.76
C50	7792810652094955.52	15585621304189111.04	S 84°14'32" E	7792810652094955.52
C51	15585621304189111.04	31171242608378222.08	S 84°14'32" E	15585621304189111.04
C52	31171242608378222.08	62342485216756444.16	S 84°14'32" E	31171242608378222.08
C53	62342485216756444.16	124684970435512888.32	S 84°14'32" E	62342485216756444.16
C54	124684970435512888.32	249369940871025776.64	S 84°14'32" E	124684970435512888.32
C55	249369940871025776.64	498739881742051553.28	S 84°14'32" E	249369940871025776.64
C56	498739881742051553.28	997479763484103106.56	S 84°14'32" E	498739881742051553.28
C57	997479763484103106.56	1994959527368206133.12	S 84°14'32" E	997479763484103106.56
C58	1994959527368206133.12	3989919054736412266.24	S 84°14'32" E	1994959527368206133.12
C59	3989919054736412266.24	7979838109472824532.48	S 84°14'32" E	3989919054736412266.24
C60	7979838109472824532.48	15959676218945649064.96	S 84°14'32" E	7979838109472824532.48
C61	15959676218945649064.96	31919352437891298129.92	S 84°14'32" E	15959676218945649064.96
C62	31919352437891298129.92	63838704875782596259.84	S 84°14'32" E	31919352437891298129.92
C63	63838704875782596259.84	127677409751565192519.68	S 84°14'32" E	63838704875782596259.84
C64	127677409751565192519.68	25535481950313038503.36	S 84°14'32" E	127677409751565192519.68
C65	25535481950313038503.36	51070963900626077006.72	S 84°14'32" E	25535481950313038503.36
C66	51070963900626077006.72	102141927801252154013.44	S 84°14'32" E	51070963900626077006.72
C67	102141927801252154013.44	204283855602504308026.88	S 84°14'32" E	102141927801252154013.44
C68	204283855602504308026.88	4085677112050086160053.76	S 84°14'32" E	204283855602504308026.88
C69	4085677112050086160053.76	8171354224100172320107.52	S 84°14'32" E	4085677112050086160053.76
C70	8171354224100172320107.52	16342708448200344640215.04	S 84°14'32" E	8171354224100172320107.52
C71	16342708448200344640215.04	32685416896400689280430.08	S 84°14'32" E	16342708448200344640215.04
C72	32685416896400689280430.08	65370833792801377760860.16	S 84°14'32" E	32685416896400689280430.08
C73	65370833792801377760860.16	130741675585602755411720.32	S 84°14'32" E	65370833792801377760860.16
C74	130741675585602755411720.32	261483351171205510822440.64	S 84°14'32" E	130741675585602755411720.32
C75	261483351171205510822440.64	522966702342411021444881.28	S 84°14'32" E	261483351171205510822440.64
C76	522966702342411021444881.28	10459334046848220428897.56	S 84°14'32" E	522966702342411021444881.28
C77	10459334046848220428897.56	2091866809369644085775.12	S 84°14'32" E	10459334046848220428897.56
C78	2091866809369644085775.12	4183733618739288171150.24	S 84°14'32" E	2091866809369644085775.12
C79	4183733618739288171150.24	8367467237478576342300.48	S 84°14'32" E	4183733618739288171150.24
C80	8367467237478576342300.48	16734934474957150684600.96	S 84°14'32" E	8367467237478576342300.48
C81	16734934474957150684600.96	33469868949914301369200.192	S 84°14'32" E	16734934474957150684600.96
C82	33469868949914301369200.192	66939737899828602738400.384	S 84°14'32" E	33469868949914301369200.192
C83	66939737899828602738400.384	133879475799657205476800.768	S 84°14'32" E	66939737899828602738400.384
C84	133879475799657205476800.768	267758951599314410953600.1536	S 84°14'32" E	133879475799657205476800.768
C85	267758951599314410953600.1536	535517903198628821907200.3072	S 84°14'32" E	267758951599314410953600.1536
C86	535517903198628821907200.3072	1071035806397257643814400.6144	S 84°14'32" E	535517903198628821907200.3072
C87	1071035806397257643814400.6144	2142071612794515287628800.12288	S 84°14'32" E	1071035806397257643814400.6144
C88	2142071612794515287628800.12288	4284143225589030575257600.24576	S 84°14'32" E	2142071612794515287628800.12288
C89	4284143225589030575257600.24576	85682864511780611510515200.49152	S 84°14'32" E	4284143225589030575257600.24576
C90	85682864511780611510515200.49152	17136572902356123021030400.98304	S 84°14'32" E	85682864511780611510515200.49152
C91	17136572902356123021030400.98304	34273145804712246042060800.196608	S 84°14'32" E	17136572902356123021030400.98304
C92	34273145804712246042060800.196608	68546291609424492084121600.393216	S 84°14'32" E	34273145804712246042060800.196608
C93	68546291609424492084121600.393216	137092583218848984168243200.786432	S 84°14'32" E	68546291609424492084121600.393216
C94	137092583218848984168243200.786432	274185166437697968336486400.1572864	S 84°14'32" E	137092583218848984168243200.786432
C95	274185166437697968336486400.1572864	548370332875395936672972800.3145728	S 84°14'32" E	274185166437697968336486400.1572864
C96	548370332875395936672972800.3145728	1096740665510791873345945600.6291456	S 84°14'32" E	548370332875395936672972800.3145728
C97	1096740665510791873345945600.6291456	2193481331021583746691891200.12582912	S 84°14'32" E	1096740665510791873345945600.6291456
C98	2193481331021583746691891200.12582912	4386962662043167493383782400.25165824	S 84°14'32" E	2193481331021583746691891200.12582912
C99	4386962662043167493383782400.25165824	8773925324086334986767564800.50331648	S 84°14'32" E	4386962662043167493383782400.25165824
C100	8773925324086334986767564800.50331648	1754785064817266997353513600.100663296	S 84°14'32" E	8773925324086334986767564800.50331648

LINE TABLE:

LINE LENGTH	BEARING
L1	S 84°14'32" E
L2	S 84°14'32" E
L3	S 84°14'32" E
L4	S 84°14'32" E
L5	S 84°14'32" E
L6	S 84°14'32" E
L7	S 84°14'32" E
L8	S 84°14'32" E
L9	S 84°14'32" E
L10	S 84°14'32" E
L11	S 84°14'32" E
L12	S 84°14'32" E
L13	S 84°14'32" E
L14	S 84°14'32" E
L15	S 84°14'32" E
L16	S 84°14'32" E
L17	S 84°14'32" E
L18	S 84°14'32" E
L19	S 84°14'32" E
L20	S 84°14'32" E
L21	S 84°14'32" E
L22	S 84°14'32" E
L23	S 84°14'32" E
L24	S 84°14'32" E
L25	S 84°14'32" E
L26	S 84°14'32" E
L27	S 84°14'32" E
L28	S 84°14'32" E
L29	S 84°14'32" E
L30	S 84°14'32" E
L31	S 84°14'32" E
L32	S 84°14'32" E
L33	S 84°14'32" E
L34	S 84°14'32" E
L35	S 84°14'32" E
L36	S 84°14'32" E
L37	S 84°14'32" E
L38	S 84°14'32" E
L39	S 84°14'32" E
L40	S 84°14'32" E
L41	S 84°14'32" E
L42	S 84°14'32" E
L43	S 84°14'32" E
L44	S 84°14'32" E
L45	S 84°14'32" E
L46	S 84°14'32" E
L47	S 84°14'32" E
L48	

**CREEKSIDE PLANNED UNIT DEVELOPMENT
A REPLAT OF PARCEL 3
OF PARTITION PLAT 1997 - 21
AND
PARCEL 2 OF PARTITION PLAT 1993 - 14
FOR
YACHATS CREEKSIDE DEVELOPMENT, LLC.**

LOCATED IN THE
**NORTH WEST 1/4 OF SECTION 26
TOWNSHIP 14, SOUTH, RANGE 12 WEST
WILLAMETTE MERIDIAN
CITY OF YACHATS
LINCOLN COUNTY, OREGON
APRIL 2008**

APPROVALS:

CITY OF YACHATS:
PLANNING CASE FILE NUMBER (1-PD-PC-05)

CITY OF YACHATS, DIRECTOR OF PLANNING _____ DATE _____

LINCOLN COUNTY:
I HEREBY CERTIFY THAT ALL TAXES ON THE WITHIN DESCRIBED
PROPERTY ARE PAID AS OF THIS _____ DAY OF _____, 2008.

LINCOLN COUNTY TAX COLLECTOR _____ DATE _____

LINCOLN COUNTY TAX ASSESSOR _____ DATE _____

LINCOLN COUNTY SURVEYOR _____ DATE _____

LINCOLN COUNTY COMMISSIONER _____ DATE _____

LINCOLN COUNTY COMMISSIONER _____ DATE _____

LINCOLN COUNTY COMMISSIONER _____ DATE _____

**REGISTERED
PROFESSIONAL
LAND SURVEYOR**

SMR

South, Smith, Martin & Ruediger, LLC
2009 South Highway 200, Unit 0-0
Pho: 503.963.0994
Fax: 503.963.5488

CREEKSIDE CREEKSIDE DEVELOPMENT, LLC
ONE EAST CAMELBACK RD. SUITE 340
PHOENIX, AZ 85012

Project: 08-002
Drawing No.: 05-0027.DWG
Field Date: 9/2007
Scale: 1"=50'
Drawn: J. FRAUENI
Field: J. PRIEST
Checked: M. RUTTEGERS
Renewal: 12/31/2008

DECLARATION:
KNOW ALL PERSONS BY THESE PRESENTS THAT YACHATS CREEKSIDE DEVELOPMENT, LLC, IS THE RECORD OWNER OF AND YACHATS CREEKSIDE, LLC, IS A CREDITOR SECURED IN THE LANDS REPRESENTED ON THIS PLAT AND MORE PARTICULARLY DESCRIBED IN THE SURVEYORS CERTIFICATE AND HAVE CAUSED THE SAME TO BE SURVEYED AND SUBDIVIDED INTO LOTS, TRACTS, EASEMENTS, AND RIGHTS OF WAYS AS SHOWN. THE STREETS CREEKSIDE LANE AND ELK MOUNTAIN ROAD, AS SHOWN, ARE HEREBY DEDICATED, COMPLETED AND SET APART TO THE USE OF THE PUBLIC FOREVER WITHOUT RESERVATION OR RESTRICTION WHATSOEVER.

K. LAYNE MORRILL (PRESIDENT OF CHESTNUT MANAGEMENT COMPANY AND MANAGER OF YACHATS CREEKSIDE DEVELOPMENT, LLC) DATE: _____

COLUMBIA COMMUNITY BANK (MANAGER OF CHESTNUT MANAGEMENT COMPANY AND OF YACHATS CREEKSIDE, LLC) DATE: _____

ACKNOWLEDGMENT:

STATE OF ARIZONA, }
COUNTY OF MARICOPA, } S.S.

THIS IS TO CERTIFY THAT ON THIS _____ DAY OF _____, 2008, BEFORE ME, THE UNDERSIGNED NOTARY PUBLIC, PERSONALLY APPEARED K. LAYNE MORRILL, PRESIDENT OF CHESTNUT MANAGEMENT COMPANY AND SOLE MANAGER OF YACHATS CREEKSIDE DEVELOPMENT, LLC, WHO BEING FIRST DULY SWORN DID SAY THAT HE IS THE RECORD OWNER OF THE WITHIN DESCRIBED LANDS AND THAT HE HAS SAID INSTRUMENT AND DOES HEREBY ACKNOWLEDGE SAID INSTRUMENT TO BE OF HIS OWN FREE ACT AND DEED.

NOTARY PUBLIC FOR OREGON _____ PRINTED NAME _____

MY COMMISSION EXPIRES _____ COMMISSION # _____

STATE OF ARIZONA }
COUNTY OF MARICOPA } S.S.

THIS IS TO CERTIFY THAT ON THIS _____ DAY OF _____, 2008, BEFORE ME, THE UNDERSIGNED NOTARY PUBLIC, PERSONALLY APPEARED _____ FOR COLUMBIA COMMUNITY BANK, WHO BEING FIRST DULY SWORN DID SAY THAT HE IS THE PERSON NAMED IN THE FOREGOING INSTRUMENT AND HAS EXECUTED SAID INSTRUMENT AND DOES HEREBY ACKNOWLEDGE SAID INSTRUMENT TO BE OF HIS OWN FREE ACT AND DEED.

NOTARY PUBLIC FOR OREGON _____ PRINTED NAME _____

MY COMMISSION EXPIRES _____ COMMISSION # _____

SURVEY CERTIFICATION:
I, THE UNDERSIGNED REGISTERED LAND SURVEYOR IN THE STATE OF OREGON, DO HEREBY CERTIFY AND SAY THAT DURING THE MONTH OF APRIL 2008, I DID ACCURATELY SURVEY THE WITHIN DESCRIBED LANDS AND RIGHTS OF WAY AND CAUSED THE SAME TO BE SURVEYED AND SUBDIVIDED INTO LOTS, TRACTS, EASEMENTS, AND RIGHTS OF WAYS AS SHOWN ON THE ATTACHED PLAT OF CREEKSIDE. THE BOUNDARY OF WHICH IS DESCRIBED AS FOLLOWS:

BEGINNING AT THE NORTH-EAST CORNER OF PARCEL 2, PARTITION PLAT 1993-14, RECORDS OF LINCOLN COUNTY, OREGON, BEING MARKED BY A 5/8" IRON ROD WITH YELLOW PLASTIC CAP STAMPED "JOHN HANNA L.S. 305", THENCE NORTH 74°19'00" WEST 174.00 FEET TO THE POINT OF BEGINNING; THENCE SOUTH 0°15'00" WEST 80.00 FEET TO THE WEST LINE OF SAID PARCEL 2; THENCE SOUTH 0°15'00" WEST 174.00 FEET TO THE SOUTH BOUNDARY CURVE TO THE RIGHT, THE CHORD OF WHICH BEARS SOUTH 60°21'42" WEST, SAID ARC PASSING THROUGH THE POINT OF BEGINNING; THENCE CONTINUING ON SAID NORTH LINE NORTH 60°45'15" WEST 22.71 FEET; THENCE CONTINUING ON SAID NORTH LINE NORTH 74°19'00" WEST 56.10 FEET TO THE NORTHWEST CORNER THEREOF; THENCE SOUTH 74°19'00" WEST 174.00 FEET TO THE SOUTHWEST CORNER THEREOF; THENCE SOUTH 74°23'25" EAST 104.52 FEET ON THE SOUTH LINE OF SAID PARCEL 3, TO THE SOUTHEAST CORNER THEREOF; THENCE NORTH 00°26'32" WEST 509.79 FEET ON THE EAST LINE OF SAID PARCEL 3 AND THE EAST LINE OF SAID PARCEL 2 TO THE TRUE POINT OF BEGINNING.

NOTES:

- THIS PLAT IS SUBJECT TO CONDITIONS OF APPROVAL PER CITY PLANNING CASE FILE NUMBER (0-PD-PC-05)
- TRACT 'D' IS SUBJECT TO THE CONDITIONS OF A 50.00 FOOT ROAD EASEMENT RECORDED AS VOLUME 18, PAGE 1786.
- PLAT SUBJECT TO CONDITIONS CONTAINED IN WARRANTY DEED RECORDED SEPTEMBER 26, 1944 IN BOOK 100, PAGE 442.
- PLAT SUBJECT TO CONDITIONS CONTAINED IN WARRANTY DEED RECORDED JANUARY 26, 1948 IN BOOK 123, PAGE 405.
- PLAT SUBJECT TO CONDITIONS CONTAINED IN REAL PROPERTY CONTRACT RECORDED APRIL 16, 1951 IN BOOK 144, PAGE 434.
- PLAT SUBJECT TO EASEMENT FOR CONSTRUCTION AND MAINTENANCE OF ELECTRIC POWER LINES CONTAINED IN EASEMENT CONTRACT RECORDED APRIL 16, 1951 IN BOOK 144, PAGE 434. DUE TO AMBIGUOUS CALLS CONTAINED IN THE DESCRIPTION THE EXACT LOCATION OF THE EASEMENT COULD NOT BE DETERMINED.

NARRATIVE:
THE PURPOSE OF THIS SURVEY IS TO SUBDIVIDE INTO LOTS, TRACTS, EASEMENTS, AND RIGHTS OF WAY THE WITHIN DESCRIBED LANDS AND RIGHTS OF WAY AS SHOWN ON THE ATTACHED PLAT OF CREEKSIDE. THE BOUNDARY OF WHICH IS DESCRIBED AS FOLLOWS:

THE BOUNDARY OF THIS PLANNED UNIT DEVELOPMENT AS SHOWN ON PARTITION PLAT NO. 1993 - 14 OF LINCOLN COUNTY RECORDS.
THE BOUNDARY FOR THIS PLANNED UNIT DEVELOPMENT WAS DETERMINED BY HOLDING FOUND MONUMENTS AS SHOWN ON PARTITION PLAT 1993 - 14, COUNTY SURVEY 17412, AND VOLUME 18 PAGE 3 OF LINCOLN COUNTY RECORDS, OREGON AND IS MORE PARTICULARLY DESCRIBED AS FOLLOWS:
THE NORTH LINE OF THE BOUNDARY WAS DETERMINED BY HOLDING THE BEARING BETWEEN MONUMENTS 'A' AND 'B'.
THE WEST LINE WAS DETERMINED BY HOLDING FOUND MONUMENTS 'D' AND 'E' AND PROLONGATING TO THE POINT OF INTERSECTION OF THE EAST LINE OF KING STREET.
THE EAST LINE WAS DETERMINED BY HOLDING FOUND MONUMENTS 'A' AND 'D'.
RECORDER'S STATEMENT:
STATE OF OREGON }
COUNTY OF LINCOLN } S.S.

I HEREBY CERTIFY THAT THE SUBDIVISION PLAT WAS RECEIVED AND DULY RECORDED IN THE LINCOLN COUNTY RECORDS ON THIS _____ DAY OF _____, 2008

AT _____ O'CLOCK _____ TARGET SHEET _____

RECORDED IN DOCUMENT NUMBER _____

BY: _____ LINCOLN COUNTY CLERK.

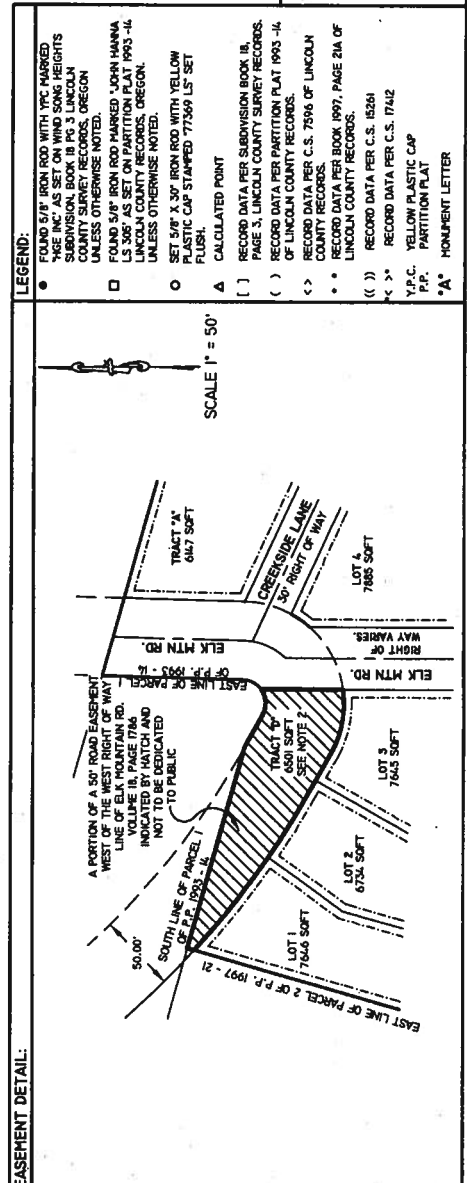

LEGEND:

- FOUND 5/8" IRON ROD WITH YPC MARKED "AGE INC." AS SET ON WIND SANG HEIGHTS SUBDIVISION, BOOK 18 PG 3 LINCOLN COUNTY SURVEY RECORDS, OREGON UNLESS OTHERWISE NOTED.
- FOUND 5/8" IRON ROD MARKED "JOHN HANNA L.S. 305" AS SET ON WIND SANG HEIGHTS LINCOLN COUNTY RECORDS, OREGON UNLESS OTHERWISE NOTED.
- SET 5/8" x 30" IRON ROD WITH YELLOW PLASTIC CAP STAMPED "77369 L.S. SET FLUSH.
- ▲ CALCULATED POINT
- [] RECORD DATA PER SUBDIVISION BOOK 18, PAGE 3, LINCOLN COUNTY SURVEY RECORDS, OF LINCOLN COUNTY RECORDS.
- () RECORD DATA PER PARTITION PLAT 1993 - 14 OF LINCOLN COUNTY RECORDS.
- <> RECORD DATA PER C.S. 7596 OF LINCOLN COUNTY RECORDS.
- RECORD DATA PER BOOK 1997, PAGE 21A OF LINCOLN COUNTY RECORDS.
- () RECORD DATA PER C.S. 16261
- < * * * RECORD DATA PER C.S. 17412
- Y.P.C. YELLOW PLASTIC CAP
- P.P.P. PARTITION PLAT
- *A* MONUMENT LETTER

EXHIBIT "C"

(Creekside Common Area Improvements)

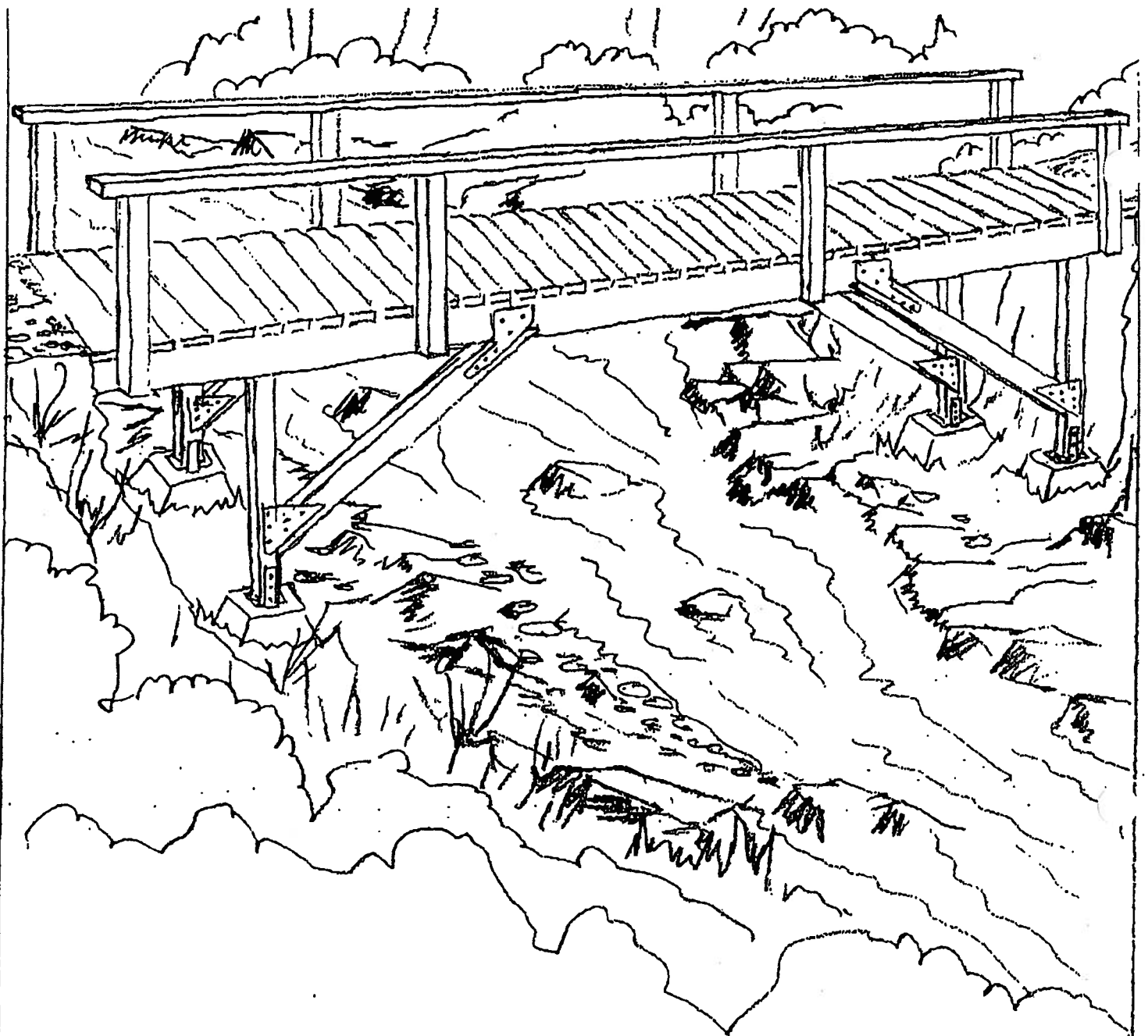

TYPICAL WALKING BRIDGE
 SCALE: NO SCALE

CREEKSIDE SUBDIVISION PUD'S YACHTS, OR	WESTERN ENVIRONMENTAL CO PO BOX 789 YACHTS, OR 971498	
DRAWING TYPE: WALKING BRIDGE, READING	PHONE: 541-547-3003	PAGE
SCALE: NO SCALE	DATE: 3/5/06	DRAWN BY: KLS 4 OF 4

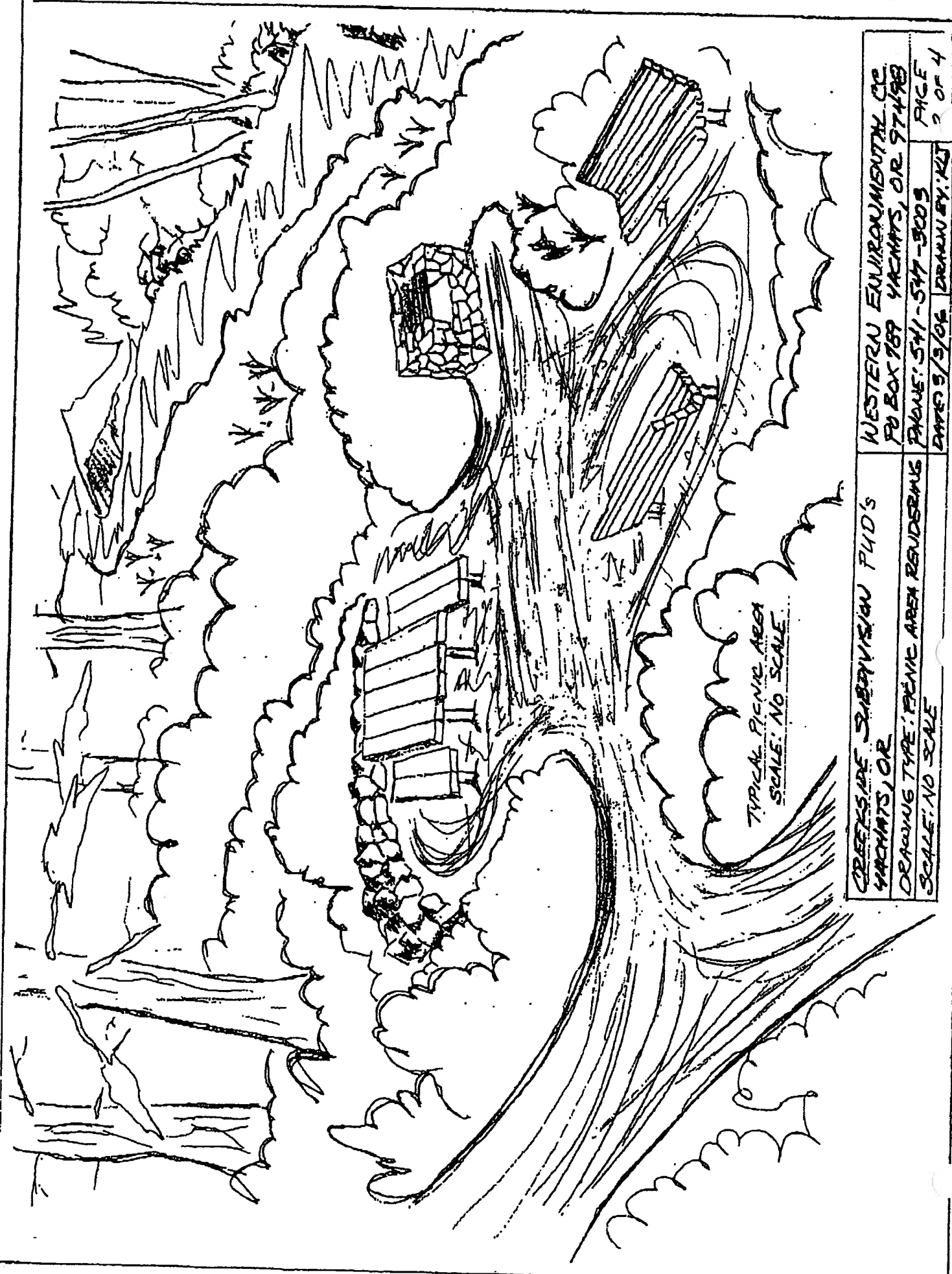

TYPICAL PICNIC AREA
SCALE: NO SCALE

CREEKSIDE SUPERVISION PUD'S
YACHTS, OR
DRAWING TYPE: PICNIC AREA RENDERING
SCALE: NO SCALE

WESTERN ENVIRONMENTAL CC
PO BOX 789 YACHTS, OR 97149
PHONE: 541-547-9809
DATE: 3/9/06 DRAWN BY: KJ

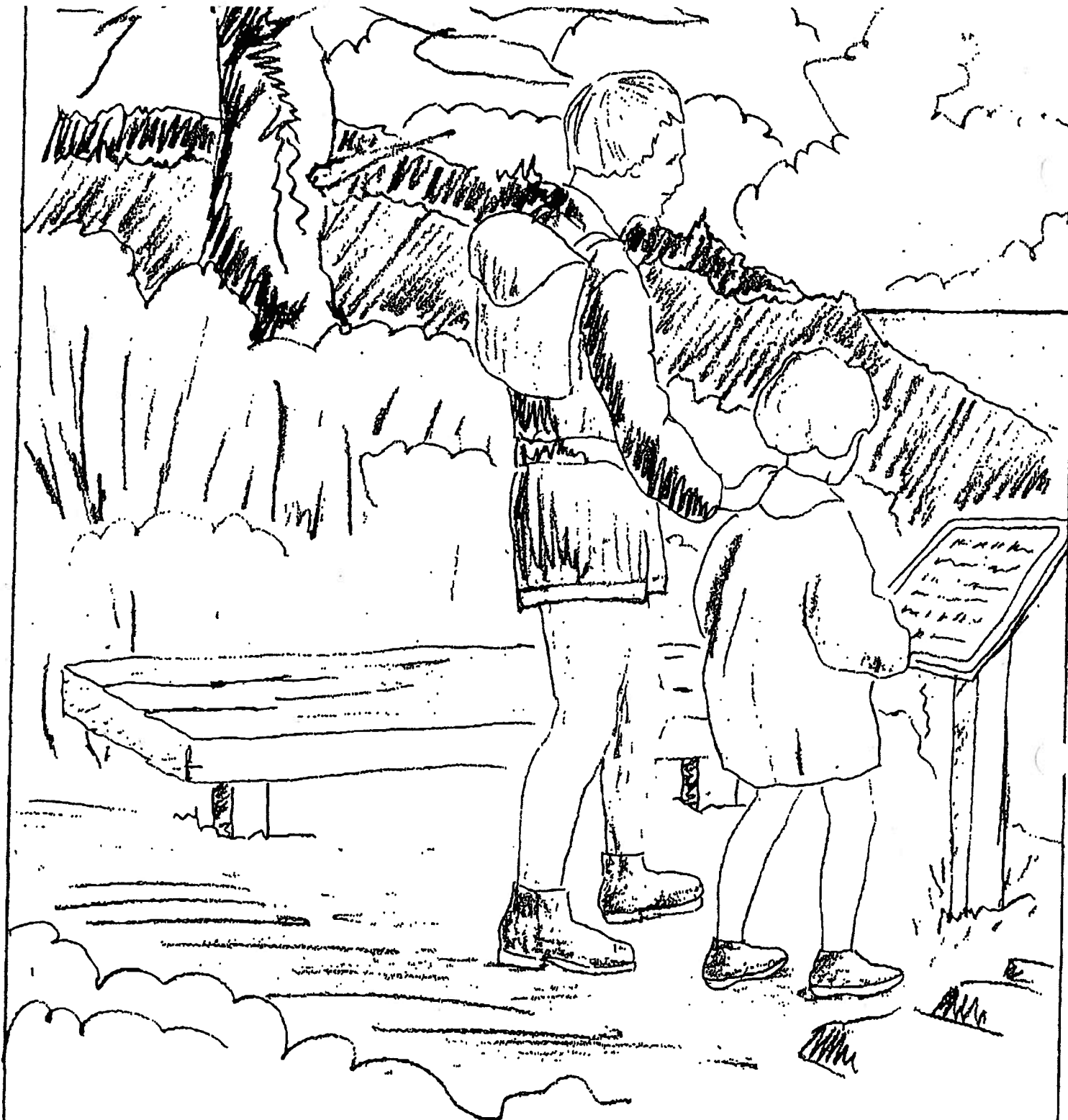

TYPICAL VIEWING AREA
SCALE: NO SCALE

CREEKSIDE SUBDIVISION PUD'S
 YACHTS, OR

DRAWING TYPE: VIEW AREA RENDERING
 SCALE: NO SCALE

WESTERN ENVIRONMENTAL CO.
 PO BOX 789 YACHTS, OR 97498

PHONE: 541-547-3003

DATE: 3/5/06

DRAWN BY: KLT

PAGE

3 OF 4

EXHIBIT "D"

(Home Orientations, Building Envelopes, and Height Restrictions)

Approximate home orientations, building envelopes, and building volumes for each Lot are as set forth on Exhibit D-1 attached hereto.

Approximate relative home building heights shall be as set forth on Exhibit D-2 attached hereto.

Approximate finish floor elevations for each Lot and number of stories permitted are as set forth on Exhibit D-3 attached hereto.

EXHIBIT "D-1"

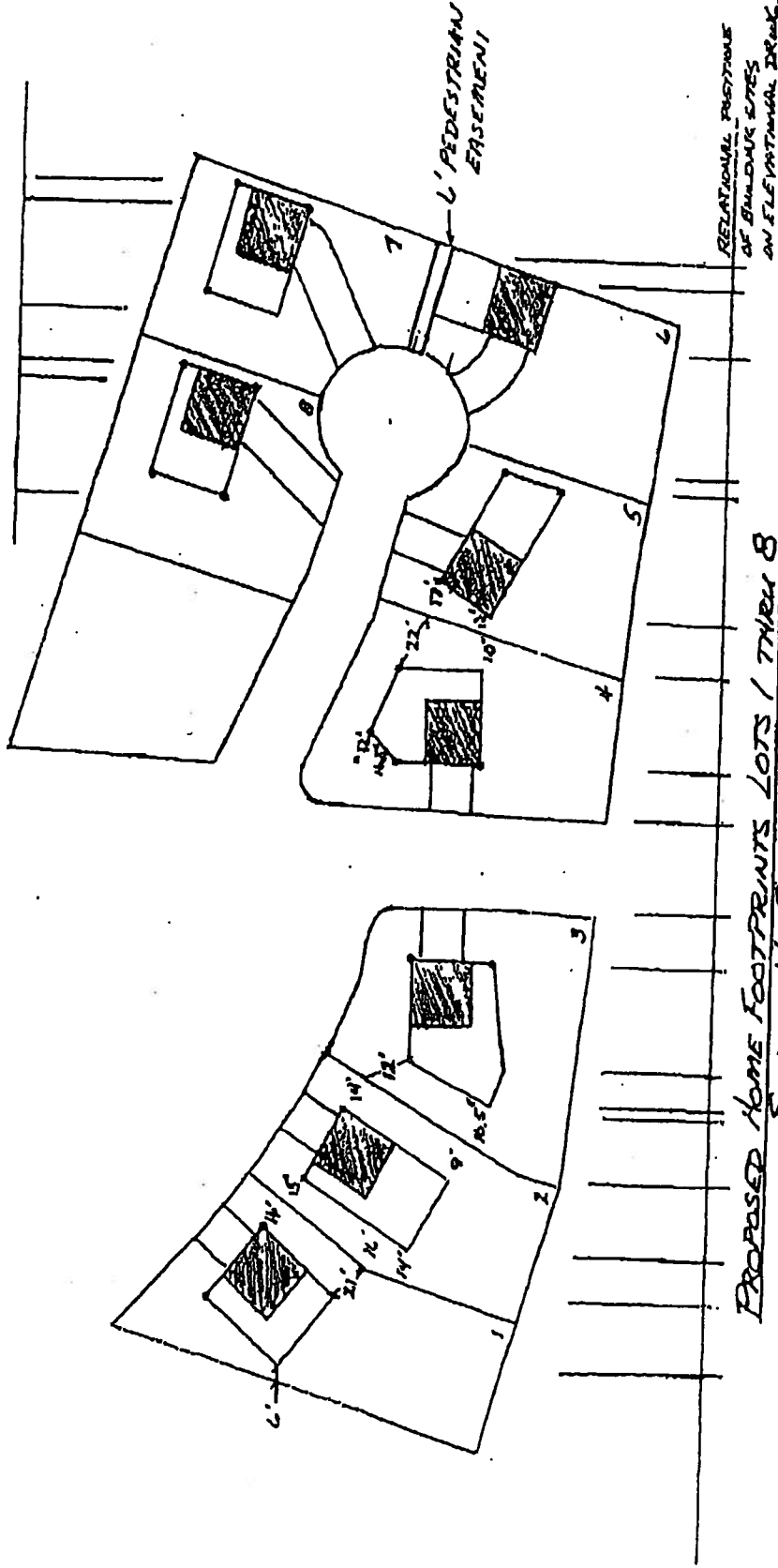

CREEKSIDE SUBDIVISION YACHTS, OR	WESTERN ENVIRONMENTAL CC
DRAWING TYPE: NO REVISION-FOOTPRINT	PO BOX 789 YACHTS, OR 971498
SCALE: AS SHOWN	DATE: 3/9/06 DRAWN BY: KLJ
	PAGE 1 OF 9

LOT # 1

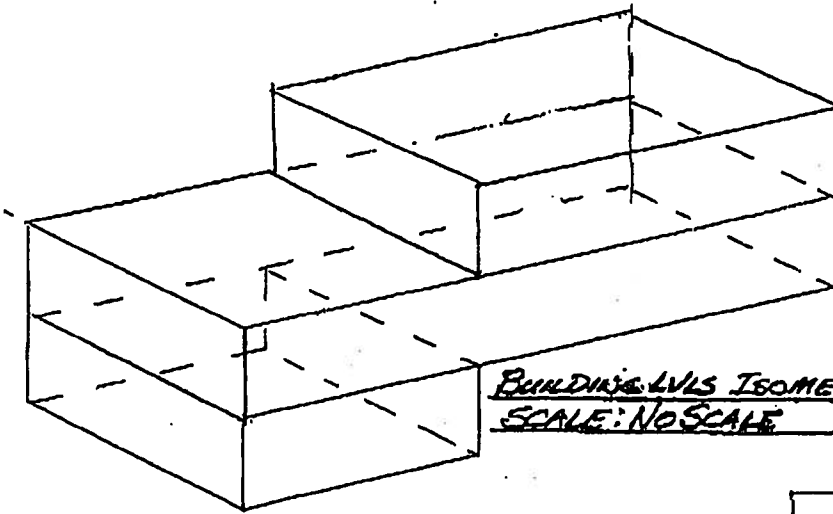

BUILDING LVLS ISOMETRIC
SCALE: NO SCALE

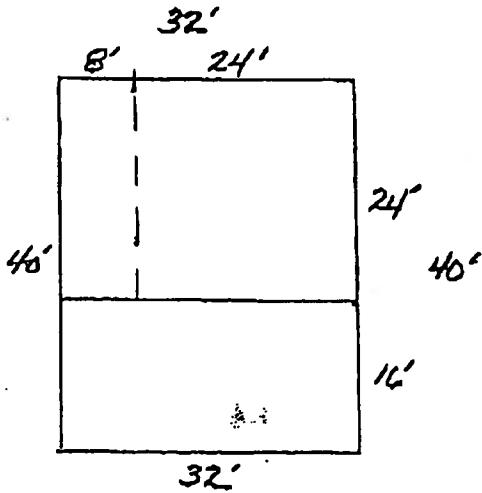

BUILDING FOOTPRINT DIMENSIONAL - LOT # 1
SCALE: 1" = 20' ±

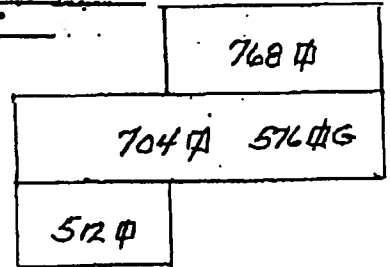

FLOOR LVLS SECTIONAL
SCALE: 1" = 20' ±

1984 sq ft LIVING
576 sq ft GARAGE

* NOT FOR CONSTRUCTION

CREEKSIDE SUBDIVISION YACHTS, OR	WESTERN ENVIRONMENTAL CO PO BOX 789 YACHTS, OR 97498	
DRAWING TYPE: NO REVISION - FOOTPRINT DETAIL	PHONE: 541-547-3009	PAGE
SCALE: AS SHOWN	DATE: 3/3/06	DRAWN BY: KLJ 3 OF 9

LOT # 2

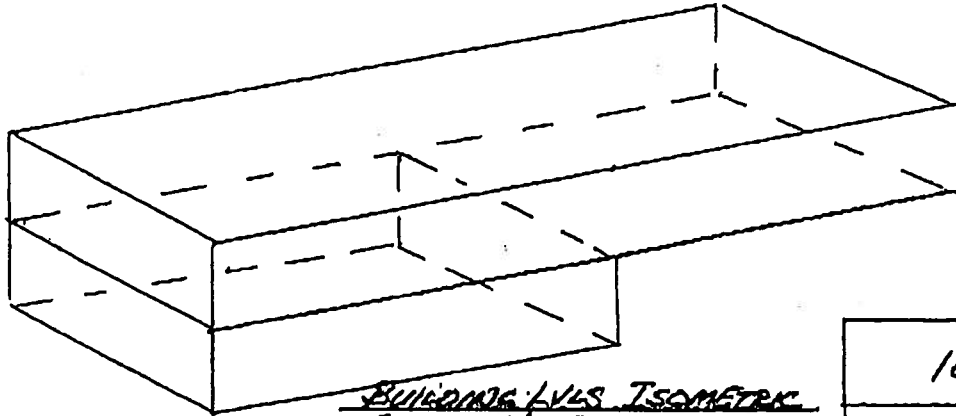

BUILDING LVLS ISOMETRIC
SCALE: NO SCALE

1096 ⌘ 576 ⌘ G

904 ⌘

FLOOR LVLS SECTIONAL
SCALE: 1" = 20' ±

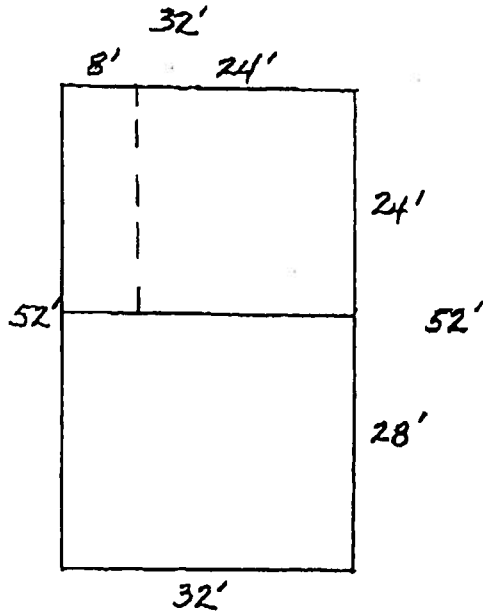

2000 ⌘ LIVING
576 ⌘ GARAGE

BUILDING FOOTPRINT DIMENSIONS - LOT # 2
SCALE: 1" = 20' ±

* NOT FOR CONSTRUCTION

CREEKSIDE SUBDIVISION
YACHTS, OR

DRAWING TYPE: NO REVISION - FOOTPRINT DETAIL

SCALE: AS SHOWN

WESTERN ENVIRONMENTAL CO.
PO BOX 789 YACHTS, OR 97149

PHONE: 541-547-3003

DATE: 3/3/06 | DRAWN BY: KIJ | PAGE 4 OF 9

LOT #3

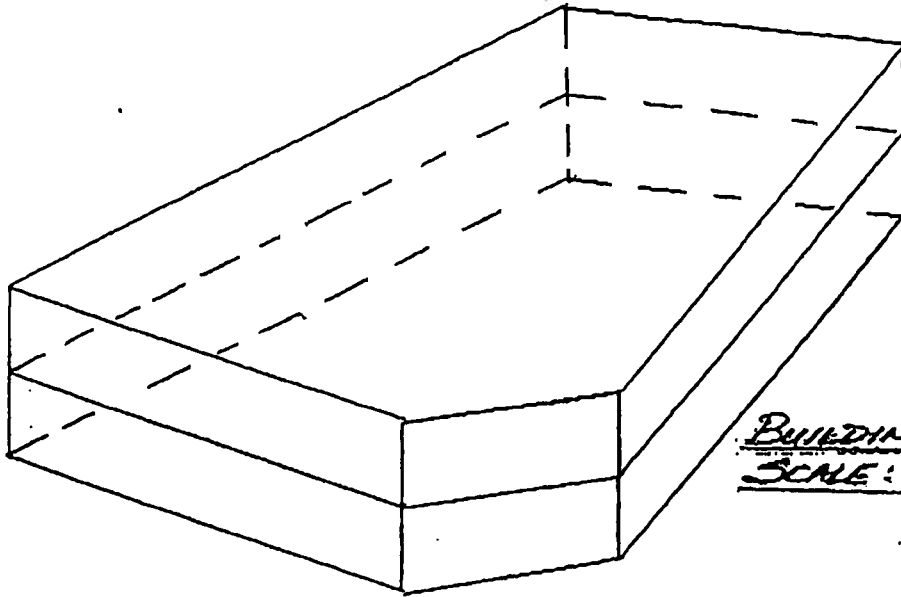

BUILDING LVLS ISOMETRIC
SCALE: NO SCALE

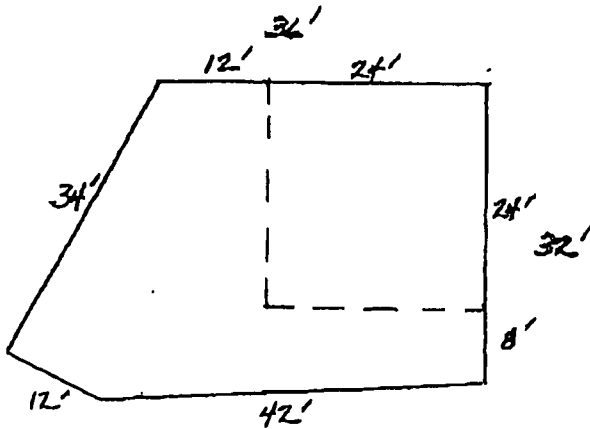

BUILDING FOOTPRINT DIMENSIONAL - LOT #3
SCALE: 1" = 20' ±

		1477 sq ft
	901 sq ft	576 sq ft G

FLOOR LVLS SECTIONAL
SCALE: 1" = 20' ±

2378 sq ft LIVING
576 sq ft GARAGE

* NOT FOR CONSTRUCTION

CREEKSIDE SUBDIVISION
YACHTS, OR

DRAWING TYPE: NO REVISION - FOOTPRINT DETAIL
SCALE: AS SHOWN

WESTERN ENVIRONMENTAL CO.
PO BOX 789 YACHTS, OR 97149B
PHONE: 541-547-3003
DATE: 3/3/06 DRAWN BY: KLT

PAGE
5 OF 9

LOT # 4

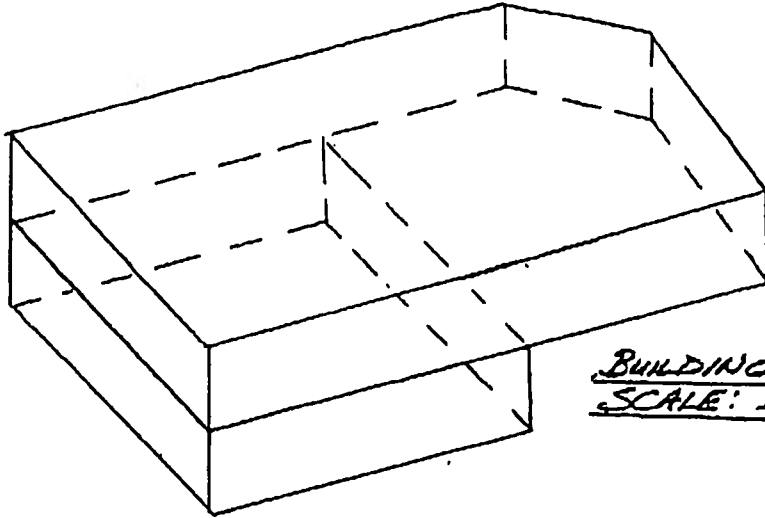

BUILDING LVLS ISOMETRIC
SCALE: 1" = 20'

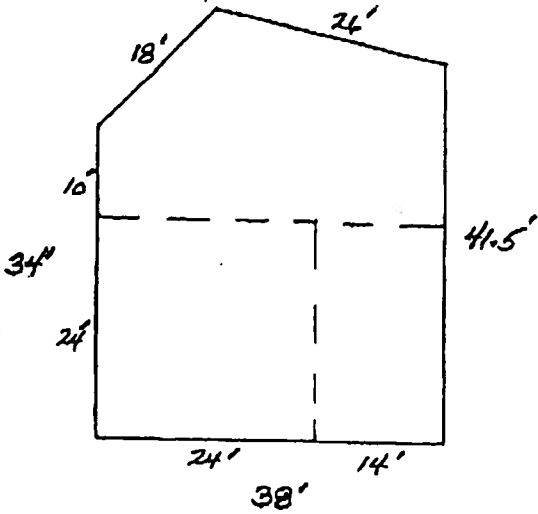

BUILDING FOOTPRINT DIMENSIONAL - LOT # 4
SCALE: 1" = 20'

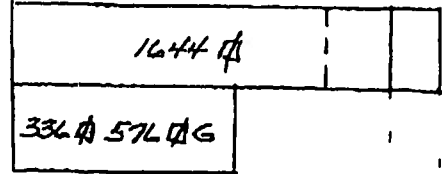

FLOOR LVLS SECTIONAL
SCALE: 1" = 20'
1980 sq ft LIVING
576 sq ft GARAGE

* NOT FOR CONSTRUCTION

CREEKSIDE SUBDIVISION
YACHTS, OR

DRAWING TYPE: NO REVISION - FOOTPRINT DETAIL
SCALE: AS SHOWN

NESTEJN ENVIRONMENTAL CO
PO BOX 789 YACHTS, OR 97149

PHONE: 541-547-3003

DATE: 3/3/06 DRAWN BY: KLT

PAGE
6 OF 9

LOT #5

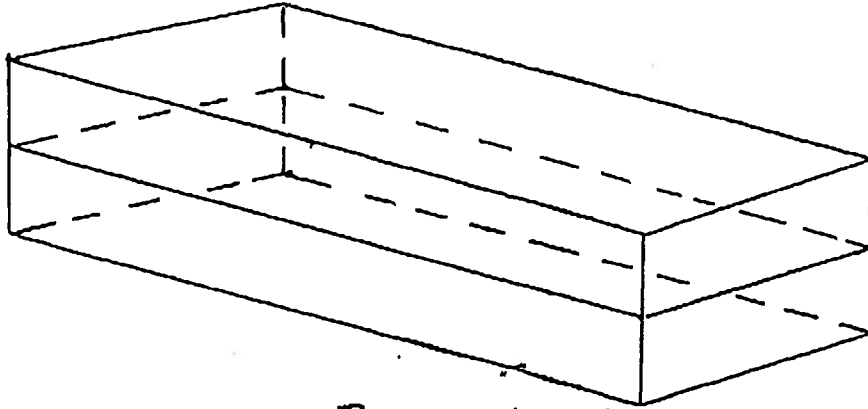

BUILDING LVLS ISOMETRIC
SCALE: NO SCALE

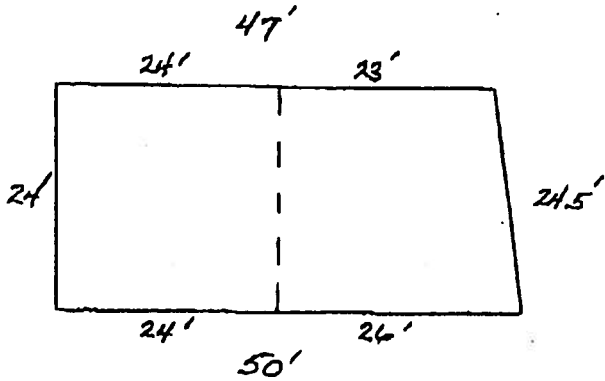

BUILDING FOOTPRINT DIMENSIONAL - LOT #5
SCALE: 1" = 20' ±

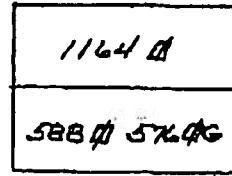

FLOOR LVLS SECTIONAL
SCALE: 1" = 20' ±

1752 sq ft LIVING
576 sq ft GARAGE

* NOT FOR CONSTRUCTION

CREEKSIDE SUBDIVISION
YACHTS, OR

DRAWING TYPE: NO REVISION - FOOTPRINT DETAIL
SCALE: AS SHOWN

WESTERN ENVIRONMENTAL CO
PO BOX 789 YACHTS, OR 97478

PHONE: 541-547-3003

DATE: 3/3/02 DRAWN BY: KLT

PAGE
7 OF 9

LOT # 6

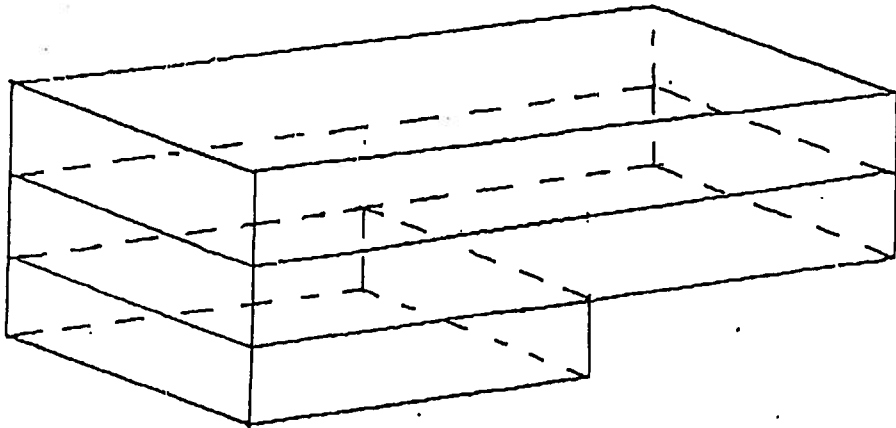

BUILDING LEVELS ISOMETRIC
SCALE: NO SCALE

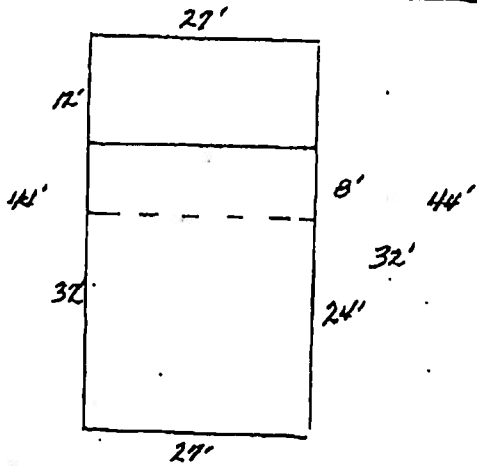

BUILDING FOOTPRINT DIMENSIONAL - LOT # 6
SCALE: 1" = 20'

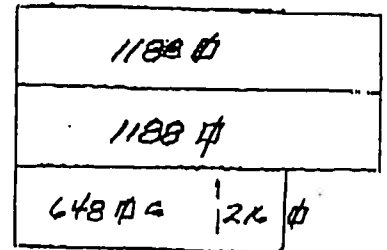

FRONT LEVEL SECTIONAL
SCALE: 1" = 20'

2572 sq ft LIVING
648 sq ft GARAGE

CREEKSIDE SUBDIVISION
YACHTS, OR

DRAWING TYPE: NO REVISION - FOOTPRINT DETAIL
SCALE: AS SHOWN

WESTERN ENVIRONMENTAL CO
PO BOX 789 YACHTS, OR 97498

PHONE: 541-547-3003

DATE: 3/3/06 DRAWN BY: KLT

PAGE
8 OF 9

LOT #7 AND LOT #8

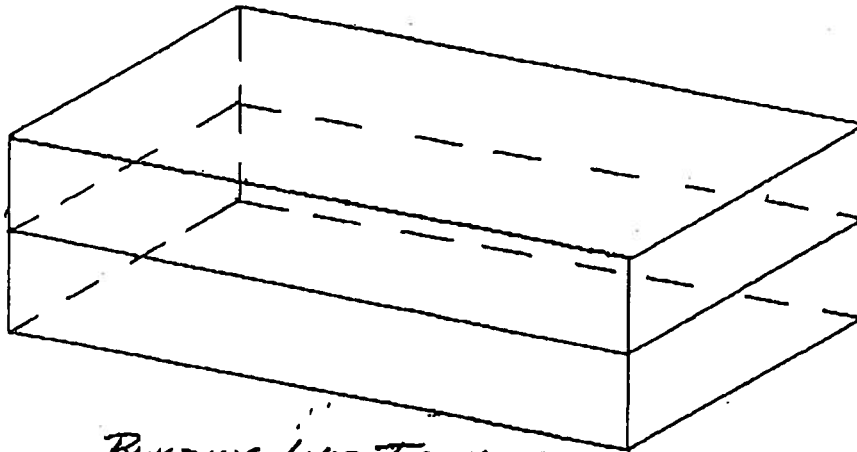

BUILDING LVLS ISOMETRIC
SCALE: NO SCALE

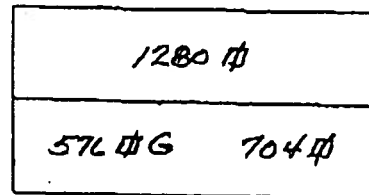
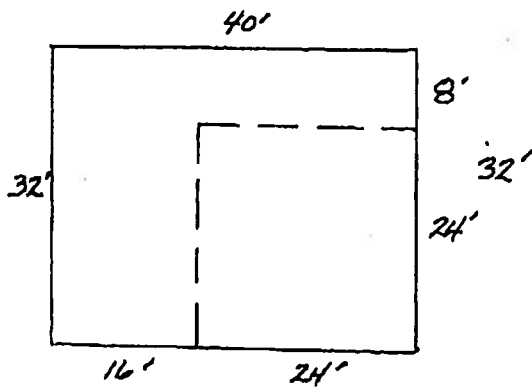

FLOOR LVLS SECTIONAL
SCALE: 1" = 20' ±

1984 sq ft LIVING
576 sq ft GARAGE

BUILDING FOOTPRINT DIMENSIONAL - LOT #7 + #8
SCALE: 1" = 20' ±

* NOT FOR CONSTRUCTION

CREEKSIDE SUBDIVISION

YACHTS, OR

DRAWING TYPE: NO REVISION-FOOTPRINT DETAIL

SCALE: AS SHOWN

WESTERN ENVIRONMENTAL CO

PO BOX 789 YACHTS, OR 97149

PHONE: 541-547-3003

DATE: 3/3/06

DRAWN BY: KLS

PAGE

9 OF 9

EXHIBIT "D-2"

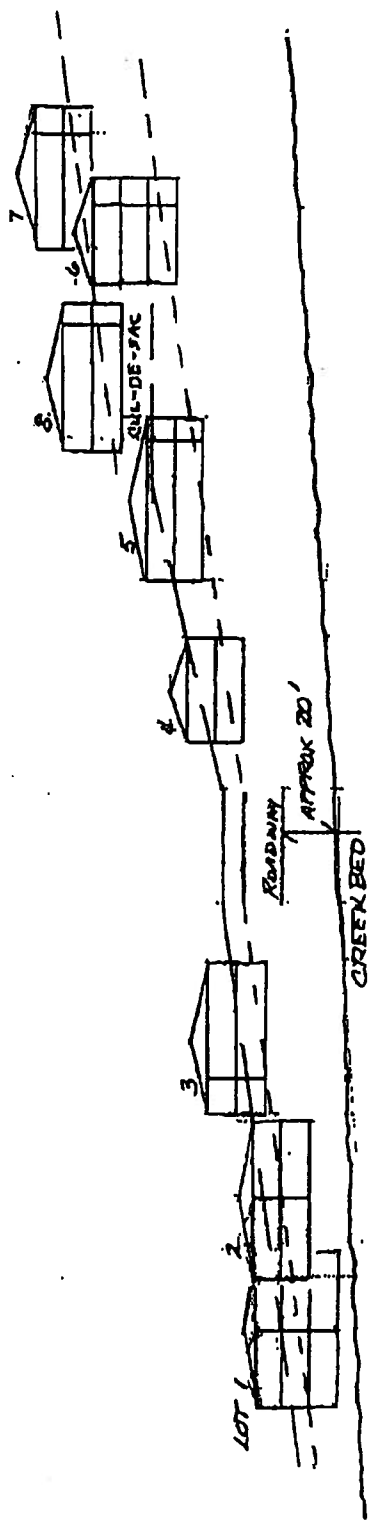

HOME FOOTPRINTS RELATIONAL ELEVATIONS

SCALE: NO SCALE

* NOT FOR CONSTRUCTION

EXISTING AND PROPOSED ROADS

MEAN LOT ELEV.

NOTE: ALL FLOOR LEVELS ARE
 DETERMINED ON 10' ELEVATIONS.
 ALL ROOF LEVELS ARE ESTIMATED
 ON 6' ELEVATIONS.

CREEKSIDE SUBDIVISION YACHTS, OR	WESTERN ENVIRONMENTAL CC
DRAWING TYPE: NO REVISION-FREV	PO BOX 789 YACHTS, OR 97149B
SCALE: AS SHOWN	DATE: 5/1-5/17-2003 PAGE 2 of 9
	DATE: 3/9/06 DRAWN BY: KLS

EXHIBIT "D-3"

<u>Lot No.</u>	<u>Approximate Finish Floor</u>	<u>Stories Permitted</u>
1	165'	Partial 2 Story With Partial Daylight Basement
2	180'	1 Story With Partial Daylight Basement
3	205'	2 Story
4	233'	1 Story With Garage And Entry Below
5	245'	1 Story With Full Daylight basement
6	265'	3 Stories (35' height limit)
7	305'	3 Stories (35' height limit)*
8	290'	1 Story With Daylight Basement

* Sketches on D-1 and D-2 regarding Lot 7 are modified by this reference.